



# Capacitor sound?

**As a first step in breaking new ground in relation to how capacitors can contribute to the 'sound' of a hi-fi amplifier, Cyril Bateman has designed a spot-frequency oscillator with sub-ppm distortion.**

**M**any capacitors introduce distortions onto a pure sinewave test signal. In some instances this distortion results from the unfavourable loading that the capacitor imposes on its valve or semiconductor driver. In others, the capacitor generates the distortion within itself.

Most properly designed power amplifiers measure less than 0.01% distortion when sinewave tested at 1kHz. This distortion percentage equates to 100 parts per million. Such small distortions are believed to be inaudible, yet people often claim to hear distortions from these amplifiers when listening to music.

Many authors claim to have identified differences in sound between different capacitor types. These differences have been ascertained not by measurements though, but by listening tests. This has led to a retrofit upgrade market supplying 'better' audio grade capacitors at substantially elevated prices compared to mass market types.

A common subjectivist claim is that oil-impregnated paper capacitors sound better than film types in valve amplifiers. Others claim that a PET capacitor sounds 'tubby' while a polypropylene sounds 'bright', and that all ceramics sound

awful. Naturally these claims have no supporting measurements.

Many writers on this topic even decry measurements, presumably in case such measurements disprove their subjectivist claims.

I have regularly received requests for advice about capacitors from readers who have read the many, often conflicting, subjectivist views about capacitor types. Over the years, these pages have also echoed to disputes between amplifier designers and music enthusiasts regarding capacitor sound distortion. These disputes culminated in a particularly acrimonious debate a year ago, during which I offered to perform some comparative measurements.

As a long term capacitor designer and measurement engineer, I believe that any truly audible differences must be both understandable and measurable. Understanding should be in terms of the capacitor constructions. Measurements may however require a change in measuring techniques.

In order to develop suitable test methods, I have measured large numbers of capacitors of many types. From these measurements, I have determined the distortion differences between capacitor constructions.



What I did not expect to find – and I find this rather disturbing – is that within a small batch of capacitors, some exhibit abnormally higher distortions. These anomalous capacitors typically exhibit some ten times greater distortion than others taped on the same card strip.

In this, the first of a set of articles, I begin to honour my commitment to quantify capacitor distortion.

### What the tests involved

Using a scheme involving a test signal at 1kHz, it is possible to differentiate between capacitor types and between good or bad capacitors within a type, **Figs 1, 2**.

In all performance plots, the 1kHz fundamental has been attenuated some 65dB using a twin-tee notch filter. The test capacitors for this article were each subjected to a three volts test signal, as measured across the capacitor terminals.

Rather than perform measurements using sophisticated equipment, I decided to develop a low-cost method that could be easily replicated by any interested reader. In doing so, I hope to improve understanding of capacitors and reduce the number of capacitor disputes in the letters pages.

### Initial investigations

Spectrum analysers capable of measuring small distortion components are prohibitively expensive for most people. I wanted to make sure that performance measurements could be made using readily available test gear like the Picoscope ADC-100 A-to-D converter or a computer sound card with FFT software.

I started by carrying out some initial capacitor intermodulation tests<sup>2</sup>. Experiments involving simple harmonic distortion testing revealed easily interpreted differences when testing less good capacitors. Testing good capacitors however confirmed that my existing signal generators introduced far too much distortion.

### A much better signal generator...

Having reviewed past low-distortion oscillator designs, I bread-boarded the more promising ones. Using these I tested a number of capacitors but with only partial success.

From these results it became clear that I needed an extremely low distortion 1kHz sine wave. I had to be able to drive at least 3 volts into a 100Ω/1μF near perfect, low distortion capacitive load, and do so without this load distorting my test signal, **Fig. 3**.

To test this near perfect capacitor, measured distortions of my complete equipment needed to be less than 1ppm, or 0.0001%. This is approaching the order of oscillator distortion produced by expensive measuring instruments such as those made by Audio Precision.

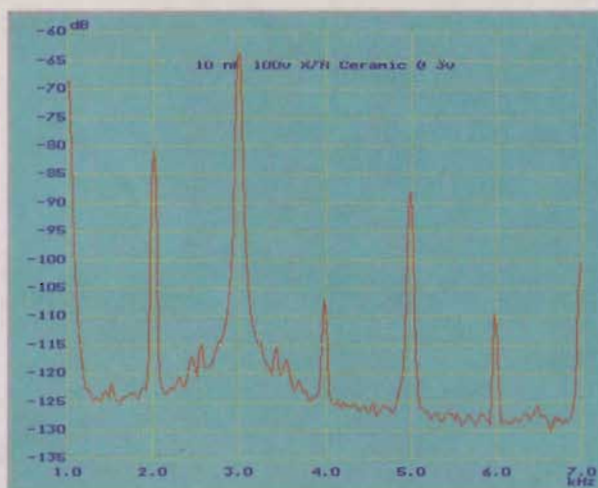
So began the design of a suitable test oscillator with a price that would be within the reach of most of you. The design of this oscillator forms the subject of this first article, **Fig. 4**.

### Initial researches

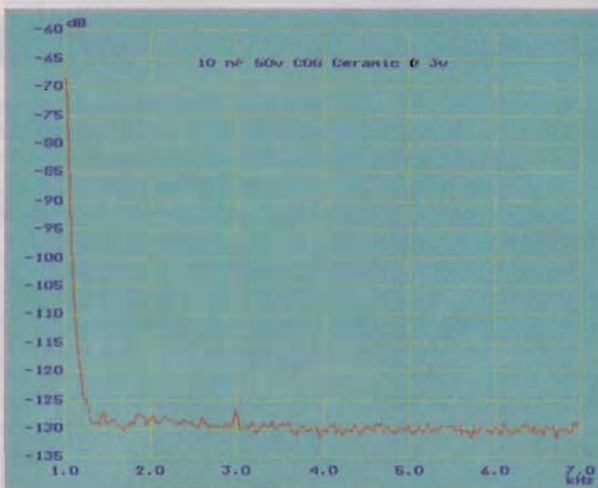
My attention was caught by a remark about “future Wien bridge oscillator design” in John Linsley Hood’s 1981 description of a 0.001% Wien bridge oscillator<sup>3</sup>. Most Wien bridge oscillators use a single amplifying stage. John suggested a method spreading the capacitor/resistor elements over two stages. This reduced the drive into his first amplifier and thus reduced its distortion.

I ran some simulations that supported John’s earlier views about lower distortion using this configuration. These simulations also suggested a possible improvement. Usually, the two Wien bridge arms use equal value components. With John’s new arrangement this results in his second amplifier having double the voltage output of his first.

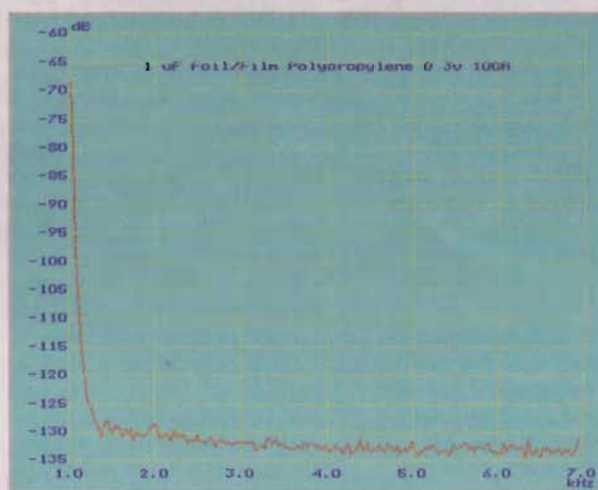
I decided to double the capacitance and halve the resistance of the series combination. This would provide equal output



**Fig. 1.** Some capacitors distort even a pure 1kHz sine wave test signal. This 10nF X7R ceramic was made by a CECC approved, European manufacturer. It was tested at 1kHz and 3 volts, in series with a 10kΩ current limiting resistor. Measurable distortion exists at all voltages down to 0.5 volts – my lowest test voltage.

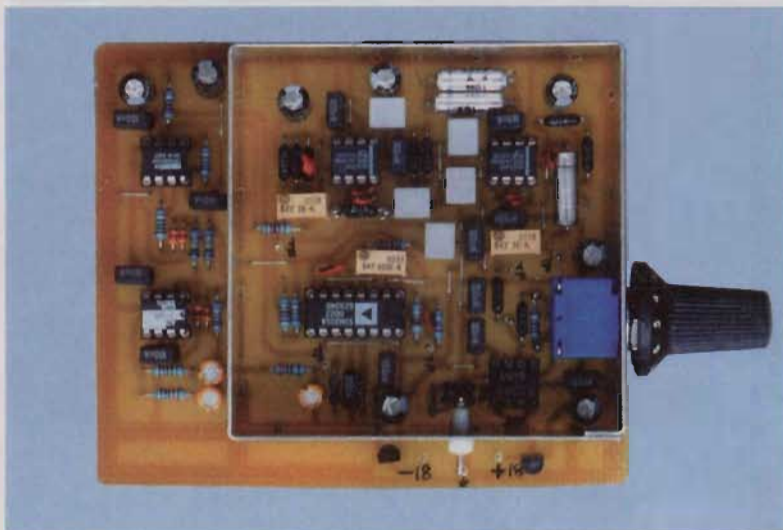


**Fig. 2.** Some capacitors distort very little. This 10nF COG ceramic was made by the same maker as Fig. 1 and co-purchased from the same distributor. Both were tested at 1kHz under identical conditions, within a few seconds of each other.



**Fig. 3.** Plot of a near perfect 1μF foil/film polypropylene capacitor, tested at 3V in series with a 100Ω current limiting resistor. It clearly shows my target test specification has been attained. This excellent result depends as much on my output amplifier design as on the oscillator. Combined distortions of my test system and 1μF load are buried in the noise floor at -130dB.





**Fig. 4. Final design for the 1kHz test oscillator, with its screening lid removed. Fitted with its lid but no other shielding and with normal fluorescent room lighting, it was used on my bench within 1 metre of the test PC for all measurements.**

### Alternative ICs and components

While I used ultra-low distortion, but expensive, AD797 ICs for  $U_1$  and  $U_2$  when building my final 1kHz oscillator, almost all its circuit development was done using low-cost NE5534A ICs. I found some 6dB difference in distortion between these two IC types in my oscillator.

I have tried other ICs for the oscillator, including the low-distortion OPA134 and OPA604. To facilitate evaluating ICs I used Harwin turned pin sockets for each position.

When using the AD797 for  $U_1$  and  $U_2$ , it is preferable to fit a 50pF capacitor between pins 6 and 8. If you are using NE5534A ICs, it is preferable to fit a 22pF capacitor instead between pins 5 and 8. Neither capacitor is needed when using OPA134 or OPA604 ICs.

The oscillator tuning capacitors must be low-distortion types, preferably 1% extended foil with polystyrene, as shown in the photograph. However I have also built satisfactory working prototypes with 1% extended foil with polypropylene and 1% metallised polypropylene, in order of preference.

Obviously a good COG ceramic capacitor would work almost as well as my first choice of polystyrene, provided the COG capacitor is available selected to 1% tolerance. My PCB provides mountings for a variety of suitable capacitors.

The value of  $VR_1$  needed to minimise distortion will vary depending on which type IC and tuning capacitors are used. I found that only the NE5534A IC provided low distortion when used for the output buffer,  $U_5$ . For this low/unity gain

position, the 22pF capacitor is essential. Also for its gain control, I found only one satisfactory variable resistor. That was a Bourns 91 series conductive plastic, obtained as 148-557 from Farnell.

Similar types may be OK too, but I have not tried them. Don't use either cermet or wirewound controls for this position though. I have tried several and they certainly do not work acceptably.

The 50pF/22pF capacitors must be low-loss, low-distortion types. Polystyrene parts are preferable, but disc ceramics – COG only – can be used. Similarly for the remaining picofarad capacitors used. I used COG ceramics for my prototypes. The PCB drawing provides for both alternatives.

In each case, my preferred IC choice is the first type listed on the schematic drawing. To produce such a low distortion oscillator it is important to use resistors having a small voltage coefficient of resistance. To ensure an easily reproducible design, I used only 0.5% Welwyn RC55C metal film resistors in the signal path. These are the black components in the photograph. These are marked as 0.5% on the schematic.

These resistors use plated steel end caps, which I prefer for reliable long term end contact stability. Many subjectivists claim non-magnetic end caps are better. I do not subscribe to that belief.

Undoubtedly, some of the oscillator output distortion is generated inside the three multi-turn Cermet trimmers. For two positions, these trimmers are essential. However the printed board does provide mounting pads for a fixed resistor, which could be substituted for  $VR_1$ , once its

voltage from each amplifier with no change in oscillator frequency. With two equal voltage output stages, I could take the amplitude control voltage from one amplifier, leaving the other able to provide my output signal.

I needed 200 $\mu$ V drive into the negative inputs of both amplifiers to produce a 3 volts output, and this arrangement promised a high 'Q' and low distortion.

Many oscillators use a thermistor to control oscillator amplitude. Distortion is then mostly third harmonic, which has been blamed on the thermistor. For my needs, third harmonic had to be minimised as much as possible. I needed a different amplitude control.

After some catalogue searching, I choose to design my amplitude control system around the Analogue Devices SSM2018P. This IC was expressly designed as a low-distortion, audio-frequency, voltage-controlled amplifier. Its lowest distortion of 0.006% at 1kHz is produced with a 3 volt input and 0dB gain. For 0dB gain, a control voltage a few millivolts above 0V is needed.

Provided that this IC's output was used to supply only a tiny portion of that drive needed to maintain oscillation, its 0.006% distortion should contribute little to the circuit's output.

I bread-boarded the circuit using a manual control voltage and with NE5534A ICs for the oscillator. Encouraged by the

value has been determined during calibration. So far I have retained use of the trimmer on my versions.

While these RC55C types could be used throughout, for economy I used my standard, inexpensive 1% metal-film resistors, for all other positions.

Three bi-polar electrolytic capacitors are used in the gain control circuits. These are the yellow-cased 'Nital' types visible in the photograph. Equally suitable are the slightly larger Panasonic BP types. Both are stocked by Farnell. Do not use a conventional polar electrolytic capacitor for these positions.

For such a low-distortion oscillator, it is essential to use good quality capacitors to decouple the power supplies. For the 0.1 $\mu$ F value, black in the photograph, I used Evox-Rifa SMR, metallised polyphenylene-sulphide film. I consider this film produces the best, small, low cost, universal capacitor. They were obtained from RS, but unfortunately the company has since stopped supplying them.

Alternatively, a good metallised PET capacitor, such as the Evox-Rifa MMK or BC Components (Philips) 470 series, should be satisfactory. I used many of both these types, in my tan $\delta$  meter project.

For the larger capacitors, I used BC Components' 1 $\mu$ F 470 series, grey in the photograph, and Rubycon YXF polar electrolytics. Again, other types should be OK but they have not been tried in the circuit.

In use the oscillator is powered from my laboratory supply, set to output  $\pm$ 18 volts.



results, I designed a simple rectifier and DC control amplifier and tested the composite assembly.

With a 3 volt drive, this set up produced the desired near 0V control voltage to the SSM2018P. Distortion however was far worse than my simulations had suggested. Time for a rethink, Fig. 5.

### Accident or design?

I returned once more to my simulations. To approximate the actual ESR losses of the tuning capacitors, I had inserted some resistance in series with each device. At some time during my many simulation runs, I had mistyped the entry of this ESR estimate for the shunt feedback capacitor. Instead of 10.0Ω I had input 100Ω. Could this explain my differing results?

Going back to my breadboard, I inserted a 1kΩ ten-turn variable resistor, set to its minimum value. I adjusted it to replicate my typographical error while measuring the circuit. To my amazement, as I increased the resistance value above 100Ω, the distortions rapidly disappeared. Why?

Certain that I had made a mistake, I repeated this adjustment and measurement many times. The results were consistent. Even better, with the variable resistor left above this value, the oscillator could be powered down and restarted, and each time it settled to the new lower distortion output, Fig. 6.

I decided to re-read the data sheet for the AD797 amplifier, which I hoped to use in my final implementations. This IC is claimed to have the lowest distortion figures of all the popular audio op-amps, but costing some £7, it is expensive.

After re-reading more carefully, I spotted a paragraph I had previously ignored. This dealt with using a small feedback capacitor ' $C_L$ ' in parallel with the feedback resistor ' $R_2$ '. "When  $R_2$  is greater than 100Ω and  $C_L$  is greater than 33pF, a 100Ω resistor should be placed in series with  $C_L$ ".

As one would with many Wien bridge and Sallen and Key filter designs, I was using a much higher feedback resistor of 15911Ω in parallel with a very high feedback capacitor of 10nF. I re-examined the data sheets for the NE5534 and several other ICs I had considered using, but did not find the same recommendation. I found that this added resistance worked well in the circuit with my NE5534A. It also worked well with all other ICs I tried in the circuit, virtually eliminating all third harmonic distortions.

### Proving the design

Accidents easily happen when bread-boarding and testing prototype designs. To avoid expensive mistakes, I used the inexpensive NE5534A devices while developing my printed circuit layout.

To stand any chance of attaining my desired low distortion, the circuit would need screening, good earthing between sections and careful supply rail decoupling. Perancea makes a 75 by 75mm PCB solder mount screening can with removable lid. It's available from Farnell. This size could accommodate just the oscillator components. The next size can was much too large. Using the smaller option required leaving my amplitude control components unscreened.

The prototype PCB layout worked extremely well, except for the output amplifier. Driven with 3 volts, my original output amplifier distorted badly. Following more breadboard experiments, the board was modified to accept another NE5534A. This was arranged as a variable gain, inverting amplifier, driving into a 600Ω load, Fig. 7.

### Choosing a gain-control pot

Choice of the gain control potentiometer was crucial. I evaluated four types, wirewound, cermet and two different conductive plastic types.

Wirewound alternatives created intolerable distortion;

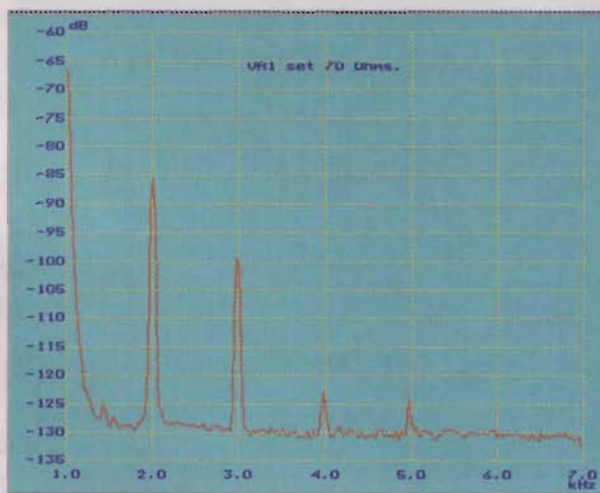


Fig. 5. Oscillator output with VR1 set to 70Ω – well below the optimum value when using NE5534A ICs. Distortion at 3 volts output measured 57ppm or 0.0057%.

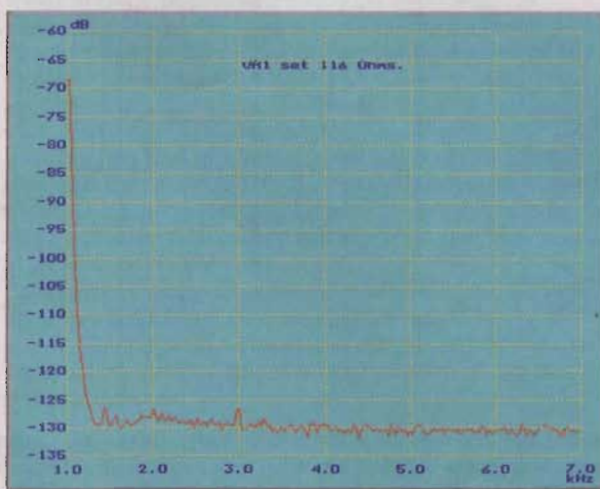


Fig. 6. Increasing VR1 to 116Ω, still slightly below optimum, distortion is now mostly third harmonic and at -126dB is well below 1ppm.

Cermets were better, but not adequate. The Bourne 91 type shown in the photograph, combined with a selected NE5534A IC, contributed almost no additional distortion when set to produce a 3 volts output, Fig. 4.

With a 600Ω load, distortion was now much lower than I could measure using either the ADC-100, my computer sound card or a Hewlett Packard 331A distortion analyser. Equipped with a passive twin-tee pre-notch filter and the above instruments I re-measured the oscillator output. Making allowance for the notch filter's reduction of the second harmonic, I estimated that at 5 volts output, distortion was approximately 1-2ppm, Fig. 8.

### Final design

Having attained what seemed a satisfactory distortion figure, I updated the printed board to accommodate this revised output amplifier. Five Vero pin test points were added to facilitate calibration. Space was provided for a couple of 'adjust-on-test' resistors and links to allow the SSM2018P to be set to either class A or AB operation, Fig. 9.

While class AB is the recommended mode and my PCB's default mode, simply linking the free end of  $R_{22A}$  to  $R_{22}$  sets the SSM2018P into class A. Set to class AB, it provides both low noise and low distortion. Reset to class A it produces a higher noise level but slightly lower distortions.

Output stage distortion of the AD797 IC can be cancelled by connecting a 50pF capacitor between its pins 6 and 8. For minimum distortion using this amplifier, the 50pF capacitor should be fitted.

If you are using the NE5534A, this 50pF capacitor must not be used. Instead, a 22pF capacitor can be connected



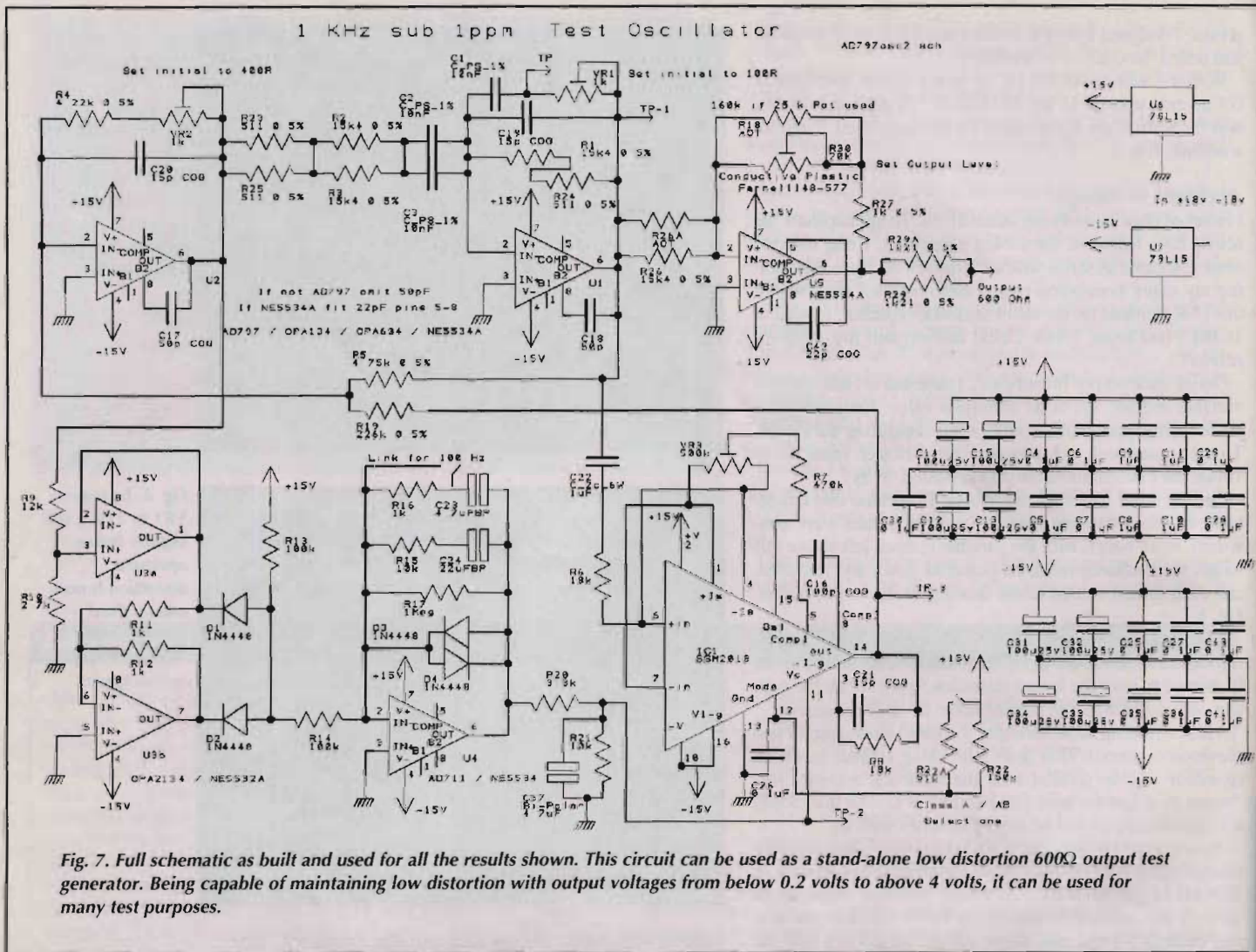


Fig. 7. Full schematic as built and used for all the results shown. This circuit can be used as a stand-alone low distortion 600Ω output test generator. Being capable of maintaining low distortion with output voltages from below 0.2 volts to above 4 volts, it can be used for many test purposes.

Other measuring methods

Early carbon-film resistors were trimmed to their final value by grinding a spiral groove into a resistive element coating on a ceramic former. Resistor noise and non-linearity was significantly reduced, compared to the older composition resistor. Incomplete or badly ground spirals frequently resulted in component failures under load.

In the sixties, engineers at Ericsson believed that non-linearities in capacitors and resistors could be detected. They measured the level of third-harmonic distortion generated in a component subjected to a very pure sine wave test signal<sup>4</sup>. Non-linearities were believed to result from badly ground resistor spirals, poor electrical contacts and the use of non-linear materials.

The engineers' original non-linearity detector design produced low-distortion test signals at 10 and 50kHz. Third harmonic distortion generated by the component under test was passed

through bandpass filters for measurement. Subsequently the 50kHz test frequency was dropped and a commercial instrument – the CLT1 component linearity tester – was produced by Radiometer of Denmark<sup>1</sup>.

To accommodate the range of component impedances and test voltages needed, a low distortion output transformer was used. Having seven adjustable tapings, it was used to tightly couple the instrument to the component under test. Component impedances from 3Ω to 300kΩ could be measured.

Today, an updated version can be obtained from Danbridge A/S, Denmark – a specialist manufacturer of capacitor test instruments. Using such equipment makes testing resistors quick and easy; however the extremely low impedance of many capacitors at 10kHz requires using extremely small test voltages. Bad and oxidised connections can be discovered. From my work though, I find detection of certain capacitor distortion

effects – especially with electrolytic types – requires a much increased test voltage.

These capacitor distortions cannot be measured at very low voltages. To avoid overstressing the test capacitor or the equipment, this increased voltage test must be performed at lower frequencies.

Extremely tight coupling between the test capacitor and the linearity tester is implicit in the CLT1 equipment design. From my early work measuring capacitors, I found it necessary to loosen this coupling in order to clearly reveal anomalies found in many modern capacitors, Fig. 1.

Using trial and error when measuring known good and bad capacitors at 1kHz, I found that 100Ω in series with a 1μF capacitor provided the best compromise between measuring current and capacitor voltage. This resistance value needs to be adjusted according to the capacitor's impedance at the test frequency used.



between pins 5 and 8. The revised circuit board provides for both options.

Note that it is crucial to use only close tolerance and low distortion capacitors for both these positions. Preferred types are 1% foil/polystyrene or COG disc ceramic.

### Final testing

To permit accurate measurements of this oscillator's distortion and facilitate calibration using either the ADC-100 or a sound card, a pre-notch filter is essential. The ADC-100 in its spectrum-analyser mode provides selectable peak input levels up to 20 volts. Its 0dB reference is fixed nominally at 1 volt.

Having 12-bit resolution, the ADC-100's dynamic range is limited to just 70dB. Most sound card a-to-d converter inputs are limited to 2 volts peak or less, but having 16 or more bits, they can provide more dynamic range.

To measure down to -130dB below 3 volts with either of the above, the fundamental should first be reduced by some 60 to 65dB. To minimise the influence of ambient interfering noise and attain a more easily measured signal, this reduced fundamental and the harmonic voltages must be pre-amplified by some 40dB.

Using a 3 volts test signal, this amplified fundamental and distortions results in a measurement voltage of around 0.3 volts RMS. To minimise wideband noise and extraneous pickup from AC mains or your PC, the signal should also be band-pass filtered.

### Making measurements

I have designed a second printed circuit board that houses a low-distortion, passive twin-tee notch filter. To permit matching the notch frequency to that of the oscillator output, the notch is tuneable by some  $\pm 10\%$  from its nominal frequency.

Nominal input impedance of the filter is  $10k\Omega$ . A high impedance unity gain, low noise pre-amp can be switched into circuit, should this passive notch loading be excessive.

Four stages of low-noise, low-distortion, amplification and bandpass filtering follow the notch filter. All measurements shown in this article were made using this pre-notch filter/pre-amplifier as the input into my ADC-100 converter.

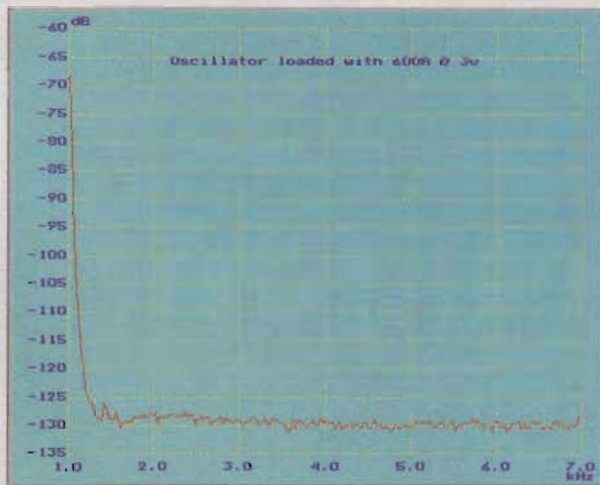


Fig. 8. Output distortion of the complete oscillator design shown in Fig. 7. Outputting 3 volts into a  $600\Omega$  load, distortion of this prototype measured using my pre-notch filter/amplifier is buried in the measurement noise floor at -128dB - or less than 0.5ppm.

While I took care to minimise noise and distortion in this amplifier/filter, obviously its contribution is included in my results. Using this method, the distortion of my oscillator into  $600\Omega$  load when built with AD797 ICs, measured less than -128dB, or less than 0.5ppm, Fig. 8.

Less expensive alternative ICs can also be used. By selecting from a batch of 10, I was able to attain an output distortion of -126 dB using the much less expensive NE5534As. There's more on this in the panel entitled, 'Alternative ICs and components'.

### Increasing signal drive

This excellent quality signal driving into  $600\Omega$  can be used to measure amplifiers, etc. However a more powerful output buffer amplifier providing increased drive current must be used when testing capacitors.

## Jung-Curl test

Some twenty years ago, a simple capacitor test method used an instrument amplifier to compare the differences between a test and reference capacitor<sup>5</sup>. These capacitors were connected in series with each of the instrumentation amplifier inputs, then subjected to a rectangular test wave, Fig. A.

This circuit formed a traditional Wheatstone bridge. Using a sinewave stimulus, a test capacitor was compared with a known reference capacitor. When a rectangular wave test signal is used though, interpretation of the output waveform was impracticable, unless both capacitors were of similar value, dielectric and construction.

For most capacitor constructions, capacitance does vary with test frequency and test voltage. For all capacitors, using dielectrics other than air or vacuum, equivalent series resistance is totally frequency dependent. Usually, ESR reduces with frequency, reaching a minimum at the capacitor's series self-resonant frequency.

Differing dielectrics and constructions thus result in small differences in ESR and impedance with test voltage and frequency. The differences simply cannot be adequately resistively nulled. This imbalance led to a variety of unsatisfactory explanations and interpretations, often

involving dielectric absorption.

Having tried and failed to reconcile the output waveforms when using previously characterised capacitors, my advice is to use this circuit only with a sinewave test signal, as a resistance or capacitance bridge.

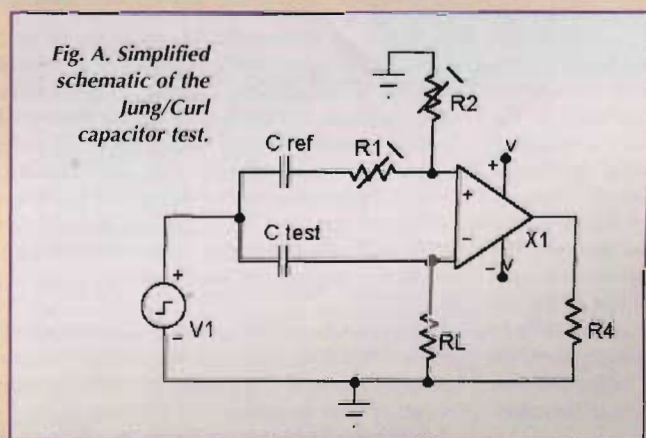


Fig. A. Simplified schematic of the Jung/Curl capacitor test.



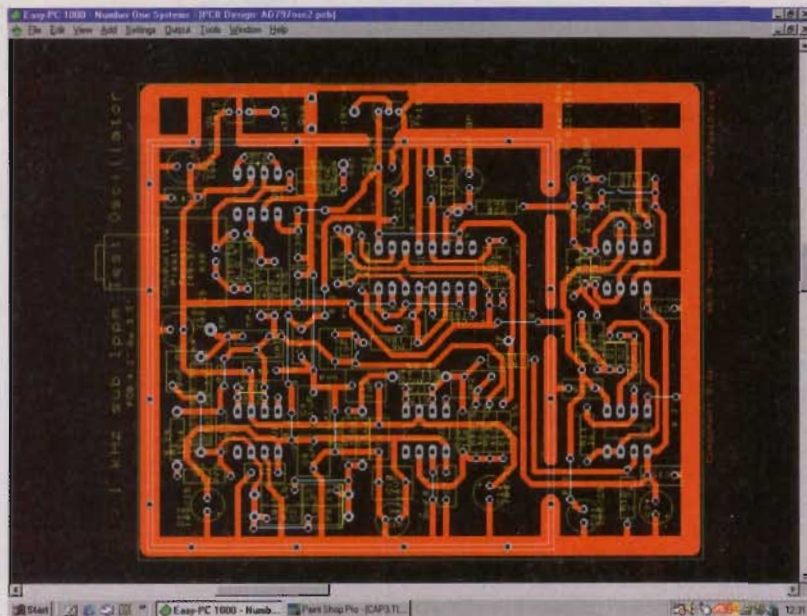


Fig. 9. Version II of the PCB design, as used for this article. The board can be assembled using a variety of oscillator ICs, and is pierced allowing a choice of oscillator capacitor styles and values. The PCB tracks have been arranged for easy one-off PCB etching and assembly.

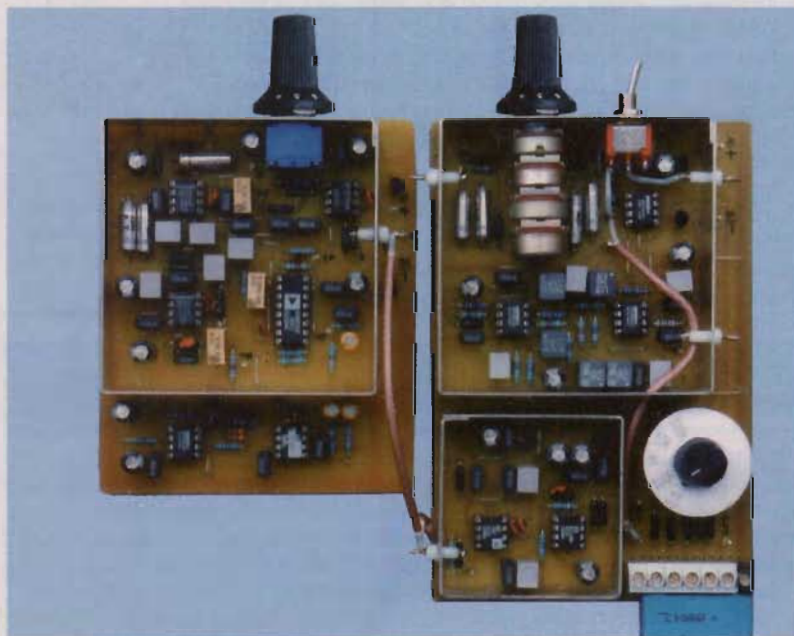


Fig. 10. Full measurement system displayed, with the test oscillator on the left and the low output impedance amplifier and pre-notch filter/amplifier on the right. This design has been used down to 100Hz and up to 10kHz by changing the Wien bridge and filter capacitor values.

Designing a suitable buffer power amplifier capable of driving into a series resistor/capacitor load without increased distortion proved difficult. It required almost as much development time as was needed for the oscillator itself.

After evaluating many potential buffer amplifier configurations, I have designed a very low distortion circuit having a gain of two and capable of driving 7V RMS or 40mA into a 100Ω/1μF capacitor combination. I have found this buffer circuit sufficient to measure distortions produced by capacitors from a few hundred picofarads up to 1μF, at 1kHz, Fig. 10.

Capacitors above 1μF are usually electrolytic types, either tantalum or aluminium. To avoid overstressing these capacitor types and maintain similar test voltages, a reduced test frequency must be used.

I have also developed an alternative buffer amplifier for measuring electrolytics. It is able to drive up to 7 volts and

400mA at 100Hz, albeit with slightly greater distortion than for my 1kHz design. Since electrolytic capacitors distort more than the lower value, better quality film and ceramic types this small increase in distortion is acceptable.

My 1kHz pre-notch filter/pre-amplifier (top box) and output buffer amplifier (lower box) can be seen in the photograph. Both will be fully described in my next article, Fig. 10.

### Calibration

Calibrating this oscillator requires a suitable spectrum analyser, distortion meter or preferably my low cost pre-notch filter/40dB preamplifier. This is shown in Fig. 10 and will be detailed in my next article.

Prior to inserting the SSM2018P, trimmer  $VR_3$  should first be set to its mid value. Similarly, prior to inserting  $U_1$  and  $U_2$ , trimmers  $VR_1$  and  $VR_2$  should be set to the starting values shown on the diagram. These values give a good starting point and should ensure the oscillator starts reliably. Output at the test point adjacent to  $VR_1/R_{26}$  should be around 3 volts.

Monitor test point 2 adjacent to  $C_{37}$  using a DC millivoltmeter. Adjust  $VR_2$  only to attain near zero volts. With the top screening cover fitted in place, allow the circuit to fully warm up for at least 20 minutes.

Observing the output spectrum at the test point 1 adjacent to  $VR_1/R_{26}$  using the high impedance preamplifier, you will probably see significant distortion products, Fig. 5.

Slowly increase the resistance of  $VR_1$  and simultaneously adjust trimmer  $VR_2$  to maintain near zero volts on the test point adjacent to  $C_{37}$ . This adjustment affects mostly the third and higher odd harmonic components.

Adjusting  $VR_1$  and  $VR_2$  will also slightly change the oscillator frequency. If you are using a pre-notch filter, re-adjust this filter tuning to maximise notch depth. Distortion products should suddenly and dramatically reduce as you approach the optimum resistance value for  $VR_1$ , Fig. 6.

Relocate your test probe to the test point 3 adjacent to  $R_8$  and adjust  $VR_2$  to minimise the second harmonic component only. This adjustment has little effect on the higher harmonics which should be ignored.

Return to monitoring the test point 1 adjacent to  $VR_1/R_{26}$  and slowly adjust all three trimmers as above to minimise distortion. This completes the oscillator calibration, Fig. 8.

Test or select  $U_5$ . Attach a 600Ω resistor load to the 'out' test point and adjust the conductive plastic potentiometer to give a 3 volts output. Monitor the distortion spectrum at this 'out' test point, and compare it with that previously attained at the test point adjacent to  $VR_1/R_{26}$ . Both should be almost identical. If not replace  $U_5$  and retest.

While monitoring the 'out' test point, you may be able to slightly reduce the overall output distortion by making small adjustments of the three variable trimmers, as above. Distortion with 3 volts output into 600Ω, should be considerably less than 1ppm, Fig. 8.

By varying the output potentiometer, the output voltage should range from less than 0.2V to more than 4V. 'Adjust on test' resistor positions have been provided for  $R_{26A}$  also  $R_{18}$  to ensure attaining this output voltage range. ■

### References

1. CLT1 Component Linearity Test Equipment data sheet, RE Instruments AS, Copenhagen.
2. 'Trial by three tones', Ivor Brown, *Electronics World* February 1991, p. 131.
3. 'Wien-bridge oscillator with low harmonic distortion', J. L. Linsley Hood, *EW* May 1981 p. 51.
4. 'Harmonic testing pinpoints passive component flaws', V. Peterson & Per-Olof Harris, *Electronics*, July 11, 1966.
5. 'If the Cap Fits', W. Jung and J. Curl, *Hi Fi News & Record Review*, April 1986.



# Capacitor sound 2



**Many capacitors introduce distortions onto a pure sine wave test signal. In some instances this distortion results from the unfavourable loading which the capacitor imposes onto its valve or semiconductor driver. In others, the capacitor generates the distortion within itself.**

## Output Buffer and Twin-Tee Notch/Pre-amp.

**M**ost properly designed power amplifiers measure less than 0.01%, or 100 PPM distortion when sine wave tested at 1kHz. Such small distortions are believed inaudible, yet users often claim to hear distortions from these amplifiers when listening to music.

As a result many articles can be found on internet and in specialist magazines, claiming to have identified differences in sound, between different capacitor types. Not by measurements, but by listening tests, having upgraded a capacitor. This has led to a retrofit upgrade market supplying 'better' audio grade capacitors, at substantially elevated prices compared to mass market types.

A common subjectivist claim is that oil

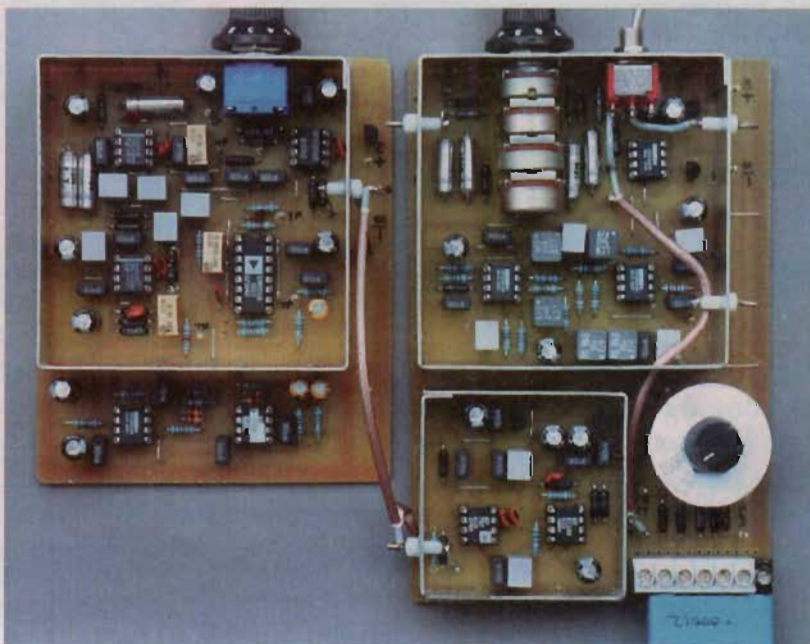
impregnated paper capacitors sound better than film types in valve amplifiers. Others claim that a PET capacitor sounds 'tubby' while a Polypropylene sounds 'bright' and that all ceramics sound awful. Naturally these claims have no supporting measurements.

A year ago, a particularly acrimonious letters page dispute arose regarding capacitor distortions. It seemed some of the issues raised could only be resolved by providing proof positive, that many capacitors do cause distortion. I offered to perform some comparative distortion measurements.

### Commitment honoured.

To measure the distortion level for most capacitors, a very low distortion generator

*Figure 1: Very low distortion, low output impedance buffer amplifier, with passive Twin Tee notch filter, bandpass filters and 40dB gain preamp printed circuit board (right). This arrangement used with my low distortion 1kHz oscillator(left), can measure capacitor distortions down to -130dB.*





complete with a matching low output impedance, low distortion, buffer amplifier must be used. An easily replicated, low cost, extremely low distortion test generator was described in my last article. Ref.1

This article describes a matching very low distortion, low output impedance, buffer amplifier needed to generate a pure sine wave voltage across a test capacitor. Having a near 600 $\Omega$  input impedance, this buffer amplifier could equally be used with many commercial generators as well as with my design. Fig. 1.

To facilitate measuring capacitor distortions using low cost instrumentation, the 1kHz test fundamental should first be attenuated some 65dB in a passive Twin Tee notch filter. Reducing the dynamic range to be measured.

Using a typical 3 volts test signal, this attenuated test fundamental plus distortion components, is reduced to a few millivolts. This small signal should be bandwidth filtered and pre-amplified by 40dB, to allow measurement using a 16 bit computer soundcard or the 12 bit Pico ADC-100 converter.

An easily built, low cost buffer amplifier together with a notch filter/pre-amplifier, has been designed on a second PCB. Together with my 1kHz test generator Ref.1 these two provide a complete system able to measure distortions as small as -130dB, 0.3 PPM or 0.00003%, below a 5 volt test signal.

To replicate common circuit drive voltages, this buffer should be able to generate up to seven volts RMS across a 1 $\mu$ F capacitor, fed via a 100 $\Omega$  current limiting source resistor.

### Test Requirement.

Perhaps you already have a low output impedance test generator. The simple method I used to decide when my equipment was suitable for capacitor distortion measurements, will determine whether your existing equipment can be used.

Using a 100 $\Omega$  source impedance, connect a 511 $\Omega$  resistor to ground. Increase the generator output so as to measure 3 volts or more across this 511 $\Omega$  using a DVM. Remove the DVM and perform a distortion measurement across the 511 $\Omega$  resistor.

If one PPM or less, replace the resistor by a good, nearly perfect 1 $\mu$ F capacitor and without changing the generator output voltage, perform a distortion measurement across the capacitor. If less than 1 PPM, the equipment can be used to measure capacitor distortions.

The best test capacitor for this would be either a COG ceramic or an extended foil/Polystyrene. These are not distributor items so are impossible to obtain in small quantities.

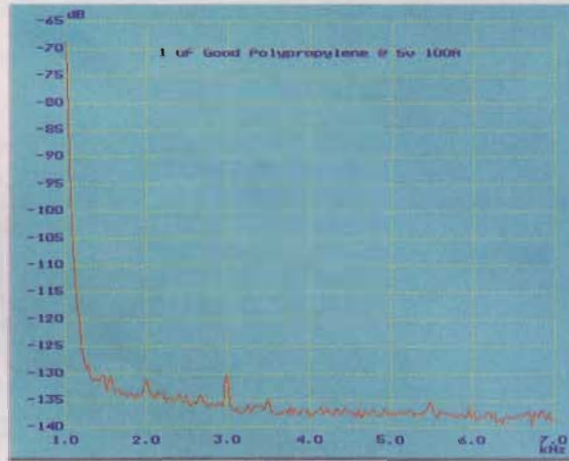


Figure 2: Plot of a near perfect 1 $\mu$ F foil and Polypropylene capacitor tested at 5 volts in series with a 100 $\Omega$  source impedance. This plot includes not only any capacitor induced distortion but also that of my test system.

Next best is an extended foil and film Polypropylene, closely followed by extended metallised film electrodes with unmetallised Polypropylene dielectric. This last, manufactured by BC Components (Philips) is stocked by Farnell as part 577-881, 0.47 $\mu$ F 250v. I used two of these, type 376 KP 0.47/250v connected in parallel. Fig. 2.

If you have a generator able to provide suitably low distortion into a 600 $\Omega$  resistive load, then my buffer amplifier may allow your generator to be used, however it is important to note that the series input resistance seen by my buffer, some 1120 $\Omega$  inclusive of the 511 $\Omega$  R38, is essential for its low distortion. This total value should not be changed.

### Buffer amplifier design.

The buffer amplifier must not itself contribute measurable distortions. Since distortion levels measured in good capacitors are -130dB, 0.3 PPM or less, designing a suitable generator and buffer amplifier was no simple task. Designing a suitable buffer amplifier required almost as much development time as was needed for my low distortion oscillator. Ref.1

To drive 7V RMS into a 100 $\Omega$ /1 $\mu$ F capacitor combination using my generator, a buffer was required with a gain of 2.

Many potential buffer amplifier configurations were bread-boarded and rejected. While able to drive a resistive load, they were not able to develop a few volts across a 1 $\mu$ F capacitor without distorting.

An open loop buffer IC, the Burr Brown BUF634P used with an OPA604 in the makers suggested circuit, worked

## Constructing the notch filter boards.

To provide a degree of notch filter tuning, a four gang variable resistor is needed, ideally it would be a well matched conductive plastic part. To fit within the screening case it cannot be larger than 18mm diameter.

I could not find a suitable four gang conductive plastic potentiometer. Alps do list a more modest four gang carbon track design, but again I did not find a supplier. Glancing through an old price list from Falcon Electronics. Ref.2 I found a four gang 4x50k $\Omega$  Alps potentiometer at £1.75, used in active crossover filters.

I ordered five potentiometers for evaluation. Apart from being rather old

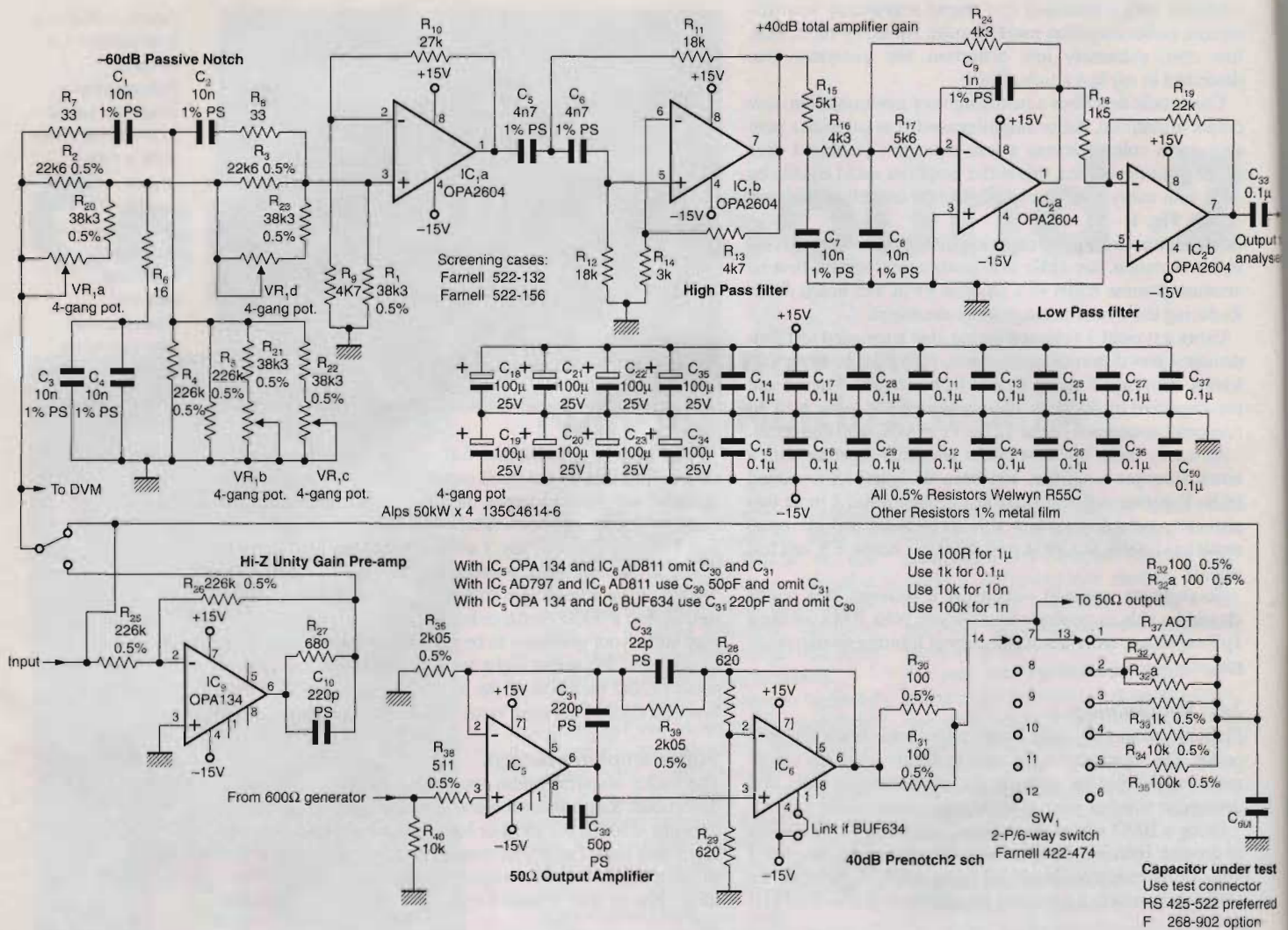
stock needing re-tinning of the terminal pins, they worked well and all were ganged closer than 1dB. I used these pots in both my 1kHz and 100Hz notch filter builds.

Since then a regular and valued correspondent, Juan from Spain, has written to me suggesting I look at the Sfernice P11 four gang 100 k $\Omega$  linear control stocked by Selectronic in France. Their part number 22.5700-1 is priced at 22.71 Euro. (<http://www.selectronic.fr>) I visited their web site several times, but the web page will not accept a UK postal code. Without a postal code, their catalogue cannot be requested. I eMailed my

request, but so far with no success.

The increased resistance of the P11 should not be a problem. To minimise potentiometer distortion, its tuning range is restricted by a 38k3 series resistor, then bridged by a 22k6 shunt resistor. With the exception of this variable control, to minimise noise and distortion and for easy replication, all resistors used in the twin tee notch filter signal path up to the first amplifier input, used 0.5% Welwyn RC55C, seen as black in the photo. To save space the four 38k3 series resistors are mounted between the potentiometer and PCB, so are hidden in the photo.





**Figure 3:** Schematic drawing of the low distortion buffer amplifier, pre-notch filter/pre-amplifier circuits shown in figure 1. The buffer amplifier at bottom, can drive more than seven volts at very low distortion, into a 100Ω/1μF test combination.

well at low drive voltages or with smaller capacitors. Loaded with a 100Ω/1μF capacitor test load, it distorted at increased drive levels. By closing one link, this combination can be used on my PCB.

The most nearly suitable circuit I tried was described in the Analog Devices AD797 datasheet. With an AD811 as the output driver, this combination claimed to be able to drive a 600Ω load to 7 volts RMS at 100kHz with less than -109dB distortion.

When breadboarded, this design produced less distortion driving into my capacitive test load than did the BUF634P circuit. For minimum distortion however, the circuit required critical matching of the impedances seen at both AD797 inputs. I was working to ensure suitable matching in November, when my only spare AD797 was damaged. Replacements not being available until February, I was forced to try other IC options. This combination of AD797/AD811 can be used in my PCB.

A low cost NE5534A worked quite well with this AD811 output stage, but again required careful input matching to minimise distortion. An OPA604 distorted at high drive, but the OPA134/AD811 worked best of all the combinations I tried.

Performance plots in this and my earlier article, were made using this OPA134/AD811 buffer amplifier.

With maximum drive into a 1μF load, the AD811 heats up, so should be fitted with a small heatsink, half of Maplin RN69. To minimise noise pickup, the circuit was screened using a small 50mm x 50mm Perancea solder mounting

screening can and lid. To reduce heat build up, eight 8mm holes were distributed around the box sides with twelve 6mm holes in the lid.

Capable of more than seven volts output, I found this buffer circuit sufficient to measure distortions produced by capacitors from a few hundred picoFarads up to 1μF, at 1kHz, Fig. 3.

**Notch filter/pre-amplifier design.**

To ensure minimal distortion of the test signal, a passive Twin Tee notch filter, with a nominal input impedance of 10kΩ is used. To track the oscillator frequency, this notch is tuneable by some ±10% from its nominal 1kHz frequency. Measuring source impedances greater than 1kΩ, the loading of this passive notch filter is excessive. A high input impedance unity gain, low noise low distortion pre-amp can then be switched into circuit.

The notch filter is followed by four stages of low noise, low distortion, amplification and bandpass filtering. To minimise hum pickup, the filtered input is 50dB down at 100Hz. To reduce high frequency input into the measuring ADC, output is 20dB down by 22kHz. Amplified by 40dB, harmonics from the 2nd to 9th are maintained flat within 0.5dB

All measurements shown in this and the previous article, were made using this pre-notch filter/pre-amplifier as the input into my ADC-100 converter.

While care was taken to minimise noise and distortion in this notch filter/pre-amplifier, its contribution is included in all my test results. Using this notch filter/pre-amplifier, the



distortion of my oscillator, built using AD797 IC's and the OPA134/AD811 buffer, driving 5V into my  $100\Omega/1\mu\text{F}$  test capacitor load, measured -130dB, or 0.3 PPM, Fig 3.

In most circuit applications, a capacitor is used either connected as shunt to ground or in series with the signal either to tailor the frequency response or simply block DC. Our test method should permit testing capacitors in either configuration.

### Capacitor jiggling

To avoid soldering the capacitor under test, some form of test jig, permitting easy exchange of various size capacitors, is required. The test jig must provide very low resistance and secure connections to the test capacitor.

I tried a number of spring contact terminal blocks. All but one required excessive capacitor lead lengths to ensure secure connections and that needed at least 5mm wires (Farnell part 268-902.) My PCB accepts this terminal block as well as the cage type below, Fig 4.

Ultimately for my own use I choose a 5mm centres, cage type, screw terminal strip, able to measure capacitors having 4mm long wires (RS part no 425-522.)

Designed to accept thick wires, it easily accepts 2.5 and 7.5mm spaced leads within its cage mouth. These cage terminals grip a wire tightly but without bending or damaging the capacitor leads. This terminal strip 'jig' was used for all 1kHz measurement plots.

The buffer amplifier/test jig shown can be used to test either series or shunt connected capacitor configurations. My preference is to shunt test, exactly as shown in the photo. The switchable current limiting resistor in series with the test signal, the capacitor being connected between signal and ground, Fig 1.

This provides two benefits:-

1) A good capacitor acts to slightly reduce any test generator harmonics, while a bad capacitor clearly shows much increased harmonic amplitudes.

2) The capacitor test voltage can be measured directly, using a high impedance meter attached to the DVM output test point. This test point measures the voltage at the input to the passive Twin Tee notch filter.

A test capacitor connected in series with the test signal, depresses the lower frequencies while slightly increasing higher harmonics, relative to the shunt connection. The test voltage can only be measured by connecting a DVM directly across the capacitor. This DVM must be removed before the capacitor can be tested.

Harmonic levels between the two methods differ by only one or two dB for the same capacitor voltage. A good capacitor looks good, and bad capacitors look bad, regardless of testing in the series or shunt connection.

By way of comparison, using a  $1\text{k}\Omega$  source impedance, I plotted test results of a known bad,  $0.1\mu\text{F}$  metallised PET capacitor, measured in both series and shunt modes at 5 volts. In comparison, the third harmonic distortion peak of a good  $0.1\mu\text{F}$  metallised PET capacitor tested at the same voltage, measures substantially lower, around -125dB. Figs 5&6.

### Series tests.

To test in the series mode, the test capacitor and current limiting resistor are simply interchanged. The test capacitor is connected to the A.O.T resistor Vero Pins and the switch is set to the A.O.T position. The current limiting resistor is fitted to the test jig terminals, replacing the test capacitor shown in the Figure, Fig 1.

### Test Capacitor Source Impedance.

The buffer amplifier output switch provides selection of four

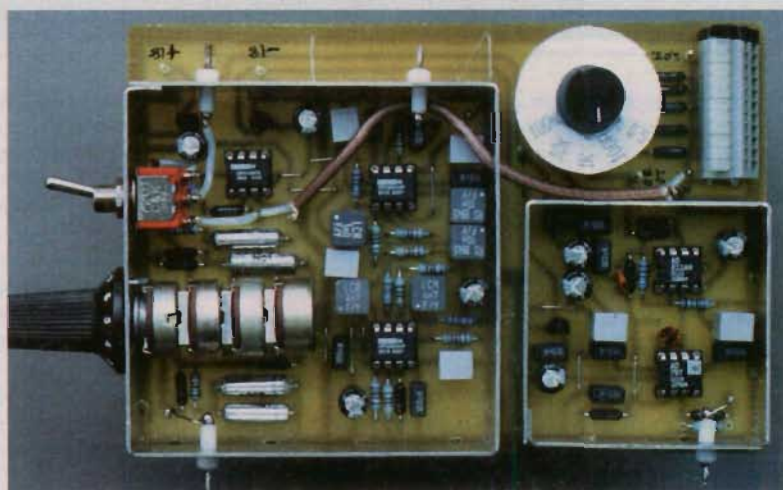


Figure 4: The PCB is double pierced so as to accept either the screw cage terminal test jig, as shown in figure 1, for capacitors with lead spacing up to 30mm. Alternately this 'spring contact' terminal strip, accepts lead spacing up to 27.5mm centres.

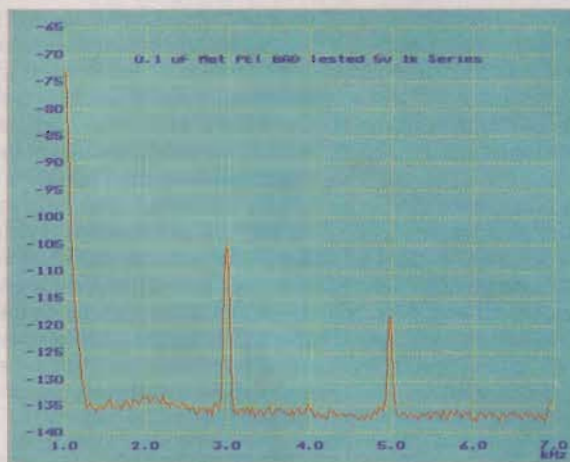


Figure 5: Distortion plot of a known 'bad'  $0.1\mu\text{F}$  metallised PET capacitor tested at 1kHz with 5 volts across the capacitor, using the optional 'series mode' connection. The capacitor is in series with the test voltage, the  $1\text{k}\Omega$  current limiting resistor, is to ground.

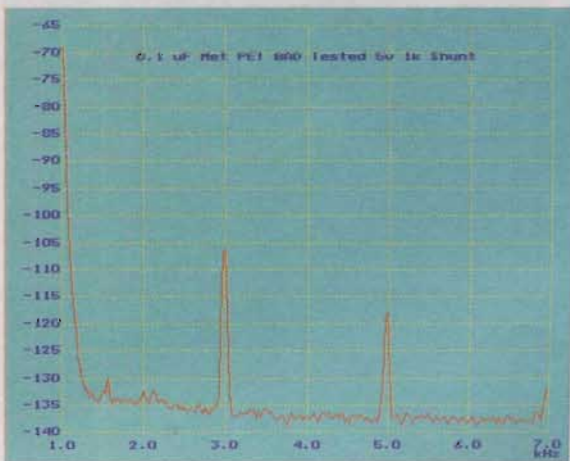


Figure 6: Distortion plot of the figure 5 capacitor and with the same 5 volts 1kHz signal, using my standard 'shunt' connection. The  $1\text{k}\Omega$  current limiting resistor in series with the test voltage, the capacitor connected to ground as in figure 1. Almost identical distortion was measured in both configurations.

values of current limiting, or source impedance resistors. In principle any resistance value can be used to test any capacitance. However this resistor value determines the maximum test voltage which can be developed across the capacitor and the test's sensitivity.

By way of illustration I plotted test results for a  $220\text{pF}$  Y5P 50v ceramic capacitor, Farnell 896-524, using each value of current limiting resistor in turn. At 1kHz a  $220\text{pF}$  capacitor has an impedance around  $720\text{k}\Omega$ .



## Other measuring methods

In the sixties, engineers at Ericsson believed that non-linearities in capacitors and resistors could be detected. They measured the level of third harmonic distortion generated in a component subject to a very pure sine wave test signal. Ref.3 Non-linearities were believed to result of badly ground resistor spirals, poor electrical contacts and non-linear materials. At that time poor contacts, especially in capacitors, were commonplace. Fortunately today, with improved techniques, poor contacts in capacitors are now quite rare.

Their original non-linearity detector design produced low distortion test signals at 10 and 50kHz. Third harmonic distortion generated by the component under test was passed through bandpass filters for measurement. Subsequently the 50kHz test frequency was dropped and a commercial instrument, the CTL1 component linearity tester, was produced by Radiometer of Denmark. Ref.4

To accommodate the range of component impedances and test voltages needed, a low distortion output transformer was used. Having seven adjustable tappings, it was used to

tightly couple the instrument to the component under test. Component impedances from 3Ω to 300kΩ could be directly measured, using source impedances from 0.05Ω to 500Ω respectively.

When testing lower impedance capacitors, the CTL1 datasheet which I still have, claimed to be able to output 0.58 A maximum. Resulting in a maximum test voltage around 100mV at 10kHz testing a 100μF capacitor. In my view this is not sufficient to reveal the true characteristics of such an electrolytic.

Today an updated version can be obtained from Danbridge A/S, Denmark, a specialist manufacturer of capacitor test instruments. Some specialist audio suppliers quote distortion levels for Electrolytic capacitors, measured using the CTL1 meter. Because of the capacitance values measured and the 10kHz test frequency, these results usually are based on extremely small test voltages. Such small test voltages will not harm the capacitor and will reveal any shortcomings in the metallic connections used in an electrolytic capacitor. However, in my experience, today these are at such low level as to

be unimportant.

Most important and relevant to audio in my view, are the inherent distortions which result from the electrolytic capacitor's diode characteristics. This diode characteristic is easily measured. Ref.5 From my test measurements at 100Hz and 1kHz, I find significant and measurable distortions when testing electrolytics, using voltages above 0.5 volts, but less so at very low test voltages. This is exactly the result to be expected from consideration of the constructions used to manufacture these capacitors.

Extremely tight coupling between the test capacitor and the linearity tester is implicit in the CTL1 equipment design. From my early work measuring capacitors, I found it necessary to loosen this coupling in order to clearly reveal anomalies, now found in many modern capacitors. By trial and error, measuring known good and bad capacitors at 1kHz, I found that 100Ω in series with a 1μF capacitor provided the best compromise between measuring current and capacitor voltage. Adjusting this resistance value according to the capacitors impedance, at the test frequency used.

Only the 100kΩ and 10kΩ plots are shown. These clearly show that as the capacitor is more and more closely coupled, then its distortion peaks look smaller. Tested with 1kΩ the third harmonic peak had fallen to -121dB and with 100Ω to -127dB. Figs 7 & 8

Readers may recall it was use of a 220pF capacitor 10kΩ resistor low pass filter combination, which sparked off considerable reader discussions last year.

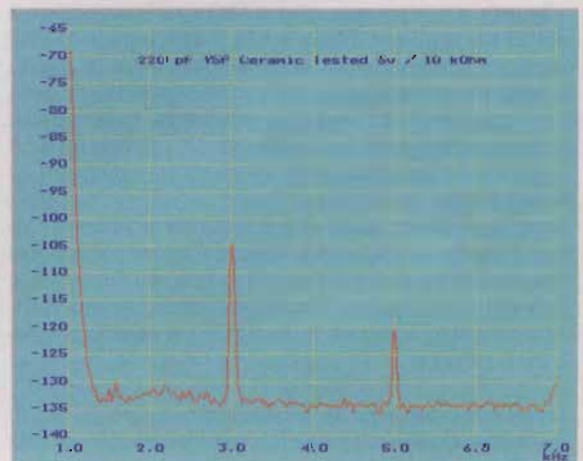
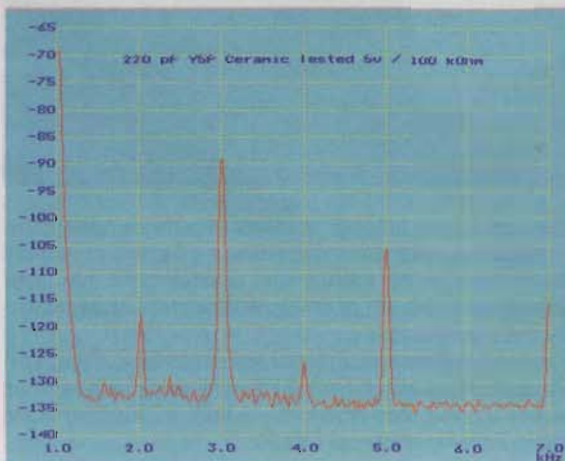
The actual value of current limiting resistor used or source impedance, determines how tightly coupled is the capacitor to the source. Using very low source and load impedances, makes even a badly distorting capacitor look relatively good. This is my main objection to the test method used by the CTL1 tester. (See box 'Other measuring methods'.)

This is a measurement quirk, the capacitor still generates

the same distortion currents, but the measurement cannot see them. Similarly when testing with reduced voltage, the distortion still exists, but can be lost in the noise floor and so not seen. From many measurements of known good and bad capacitors, I found that a compromise between these impedance extremes should be used. Using a 100Ω current limiting resistor with a 1μF capacitor gave the best and most consistent results. Good capacitors looked good and bad capacitors looked very bad.

**Figure 8: Distortion plot of the figure 7 capacitor, tested exactly the same except for the current limiting resistor, now 10kΩ. Because the capacitor is more tightly coupled to the very low distortion test source, its distortions are partially decoupled, so appear much smaller.**

**Figure 7: Distortion plot of a 220pF Y5P disc ceramic capacitor tested using a 100kΩ current limiting resistor and with a 5 volts 1kHz test signal across the capacitor. Clearly shows significant distortion products when tested using this source impedance.**





## Alternate IC's/Components.

To produce a low distortion notch filter it is important to use resistors having a small voltage coefficient. To ensure an easily reproducible design, I used 0.5% Welwyn RC55C metal film resistors, visible as black in the photograph, in the signal path. These are marked as 0.5% on the schematics. These resistors use plated steel endcaps, which I prefer for reliable long term end contact stability. Many subjectivists claim non-magnetic endcaps are better. I do not subscribe to that belief.

Having emerged from the notch, the fundamental signal has been reduced to a

few millivolts, so my usual 1% resistors can be used. Amplified by 40dB, the maximum output signal is still less than 0.5 volts.

Low distortion, low noise ICs must be used in this amplifier circuit. In my tests I found the OPA134 worked better than the OPA604 for high input levels, but found the reverse when amplifying the tiny voltages output from the notch filter. For my builds I used OPA134 for the high input impedance, high level, switchable pre-amp U9 and OPA2604 dual IC's for the low level amplifier stages U1, U2. In

each case my preferred IC choice is the first type listed on the schematic drawing. To facilitate evaluating IC's I used Harwin turned pin sockets for each position.

Similarly for capacitors, those used in the notch filter must be low distortion and for the 1kHz version, 1% COG ceramic or extended foil/Polystyrene types only should be used. At 100Hz which requires 100nF, such capacitors are not easily obtained. Foil/Polypropylene then metallised Polypropylene, in order of preference, can be used.

Thus I would normally use the 100k $\Omega$  source impedance when measuring test capacitors of 1nF and below. Whether these measured capacitor distortions are audible or not depends on the capacitor's location in the circuit, the subsequent gain of the circuit, capacitor voltage drive levels and whether the capacitor is inside or outside the negative feedback loop. Since I cannot determine that, my object was simply to prove absolutely, using easily repeatable methods, that many capacitors can and do distort a very pure sine wave test signal.

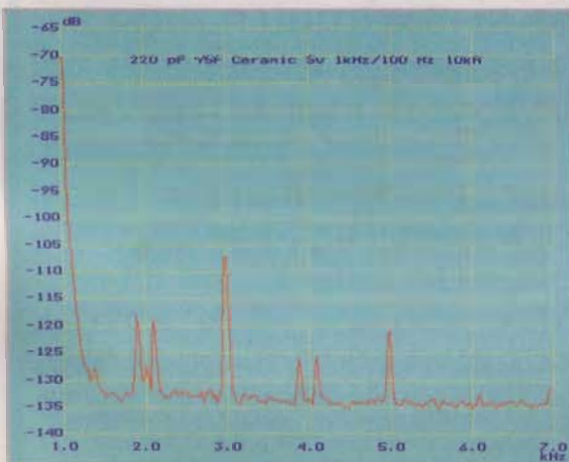
### Intermodulations.

Is it not possible that any measurable capacitor distortion using a single tone test signal, say distortion greater than -120dB, will be made many times worse, when subject to a multiplicity of signals?, thus contributing notable intermodulation distortion.

Intermodulation distortion measurements of such capacitors using just two pure tones, 100Hz and 1kHz, do show a multiplicity of distortion products, almost regardless of dielectric. Similar intermodulation distortions have been measured in bad metallised film capacitors, i.e. those which show significant distortion above -120dB, using a single tone. Testing good capacitors with the same two tones, resulted in no intermodulation products being seen.

Comparing the single tone test in figure 8 with the dual

**Figure 9:** A dual test frequency intermodulation distortion plot, 100Hz and 1kHz, of the capacitor shown in figure 8. Made using the same voltage and source impedance. Notice the appearance of new distortion products around 2kHz and 4kHz, not present when using the single test frequency. Bad metallised film capacitors exhibit similar distortions.



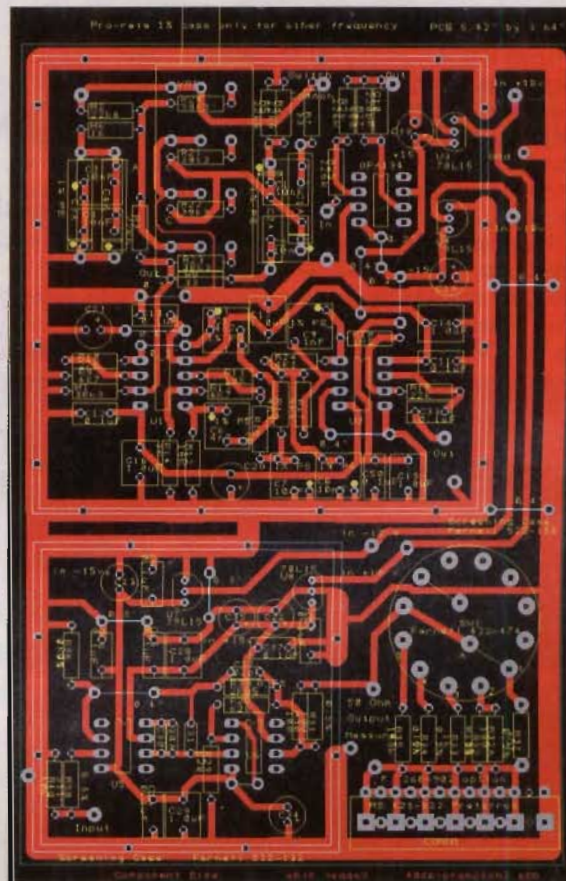
tone test in figure 9, we see distortion products around 2kHz and 4kHz in this dual tone test. They are not visible in the single tone test, even though both tests used the same capacitor, voltage levels and source impedance. **Figs 8 & 9**

The level of distortion measured is naturally dependant on capacitor style, construction and the AC voltages present across the capacitor terminals.

### Measurement equipment

I have designed a second printed circuit board, similar to that housing my test oscillator which provides both the buffer amplifier and notch filter/pre-amplifier needed to complete a measurement system. The buffer amplifier section is designed so it can be easily separated from the notch filter/pre-amplifier if desired. **Figs 10**

For values above 1 $\mu$ F, it is common practise to change to using electrolytic types, both tantalum and aluminium. To avoid overstressing such capacitors while maintaining simi-



**Figure 10:** The version II printed board designed for my 1kHz notch filter/pre-amplifier and low distortion buffer amplifier. This arrangement was used for all measurement plots in this and my previous article. The board is multi-pierced to allow the widest possible choice of Twin Tee notch and band-pass filter tuning capacitors.



## Soundcard FFT Software.

In this and my earlier article I used my Pico ADC-100 for all measurements, with the latest software downloaded from their site. However many readers will not have this ADC and wish to use a soundcard instead. A modern low cost PCI card with FFT software can provide improved capability, measuring even smaller distortions using my instruments,

than is possible using the ADC-100. The software I choose to use for the remainder of this series, is the 'Spectra 232Plus' FFT software. It can be downloaded from:

[www.telebyte.com/pioneer](http://www.telebyte.com/pioneer)

Should you have only an older ISA soundcard, some software may not work. One that will, is FFT.EXE, a DOS

program by Henk Thomassen. This can be found on the internet, also the Elektor 96-97 software CD-ROM.

Users having a modern PCI soundcard will find a very large variety of programs, often available as freeware, on the internet. One site which links to some of the better packages is: [www.pcavtech.com/links/index.htm](http://www.pcavtech.com/links/index.htm).

lar test voltages, a reduced test frequency must be used. I developed an alternative buffer amplifier, able to drive up to 7 volts and 400mA at 100Hz, albeit with slightly greater distortion than for my 1kHz design. Since electrolytic capacitors distort more than the lower valued better quality film and ceramic types, this small increase in distortion is acceptable.

The printed circuit boards for my 100Hz and 1kHz generators are identical. The only component differences are the three low loss tuning capacitors, C1, C2 and C3 which are 100nF 1% for 100Hz. One resistor value, R16 is 1k $\Omega$  for 1kHz but 0 $\Omega$  for 100Hz. Pads for a wire link have been provided.

The 100Hz notch and bandpass filters are also based on the 1kHz design and need ten times capacitance values for 100Hz. The board layout accepts the Vishay 100nF 1% MKP capacitors (Farnell 303-8609), also 47 nF (Farnell 303-8380.) Smaller capacitances were provided using the same capacitor types used for the 1kHz design. However, as can be seen in the photo, the buffer amplifier section of this PCB layout is quite different. **Figs 11**

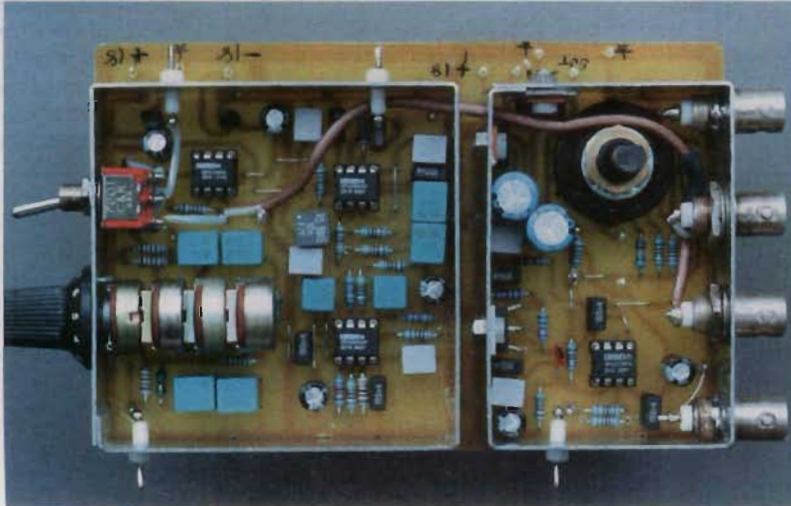
The full schematic and PCB layout for this 100Hz version will be included in a future article, 'Testing Aluminium and Tantalum electrolytics'.

### Capacitor Tests

Having tested one capacitor of a make and type, what guarantee does this give about harmonic distortions generated by other similar capacitors in the same batch? In my view that depends totally on the method of manufacture and the particular dielectric used. For the audio perfectionist however, perhaps every signal path capacitor should be distortion measured.

For example, COG ceramic is probably the most stable and most nearly perfect of all commonly used dielectrics. COG disc and multi-layer ceramic capacitors do not rely on pressure contacts or metal spray connections onto their electrodes. One maker's products should measure consistently

**Figure 11:** Photograph of the 100Hz version printed board assembly complete with BNC sockets allowing use with Hewlett Packard test jigs or four separate coax cables. The board is identical to figures 4 and 10, except for the tenfold increase in tuning capacitor values and the higher output current buffer amplifier, designed around an Elantec EL2099C integrated amplifier.



### Technical Support

Professionally produced printed circuit boards for the 1kHz low distortion signal generator, the 1kHz low output impedance buffer amplifier/notch filter/pre-amplifier boards and the 1kHz DC bias buffer will be available.

Full details of price and availability will be provided in my next article of this series, which will also include details of my DC bias buffer circuit and PCB.

and with remarkably low distortion. Those from a different maker may measure slightly differently, but again should be consistent from batch to batch.

Polystyrene is another of the best performing capacitor materials. Capacitors made using the extended foil technique and with their lead out wires soldered directly onto the extended foil electrodes, should be consistently nearly perfect. Distortions in capacitors made using metal spray end contacts to their metallised film dielectric electrodes, for any one film type, will vary more from maker to maker. Worse still, from my measurements, they can also differ considerably even within a small capacitor batch.

Some film capacitor makers however do seem remarkably consistent within a batch and from batch to batch. With other makers I have measured some 20-30dB different harmonic levels, in quite small batches, even when the capacitors have been supplied taped to card strips.

Having provided a usable, repeatable test method and easily assembled, low cost test equipment, my next articles will explore which capacitor types produce the least harmonic distortion, according to capacitance value. When possible I shall try to explain how different capacitor constructions can affect the harmonic distortion generated in the capacitor.

With so many capacitor suppliers available, I cannot provide a best buy list. This measurement hardware, which allows repeatable capacitor distortion tests, I feel should be more than sufficient.

My next article will discuss capacitors having values up to 10nF and soundcard FFT measurement software available on Internet. ■

### References.

- 1 Capacitor Sounds part 1 C.Bateman EW July, 2002
- 2 Quad Ganged 50k Linear Alps Pots. Falcon Electronics. Norfolk. 01508 578272
- 3 Harmonic testing pinpoints passive component flaws. V.Peterson & Per-Olof Harris. Electronics July 11, 1966.
- 4 CLT1 Component Linearity Test Equipment data sheet. RE Instruments AS. Copenhagen.
- 5 Understanding capacitors - Aluminium and tantalum Electronics World June 1998 p.495. C.Bateman



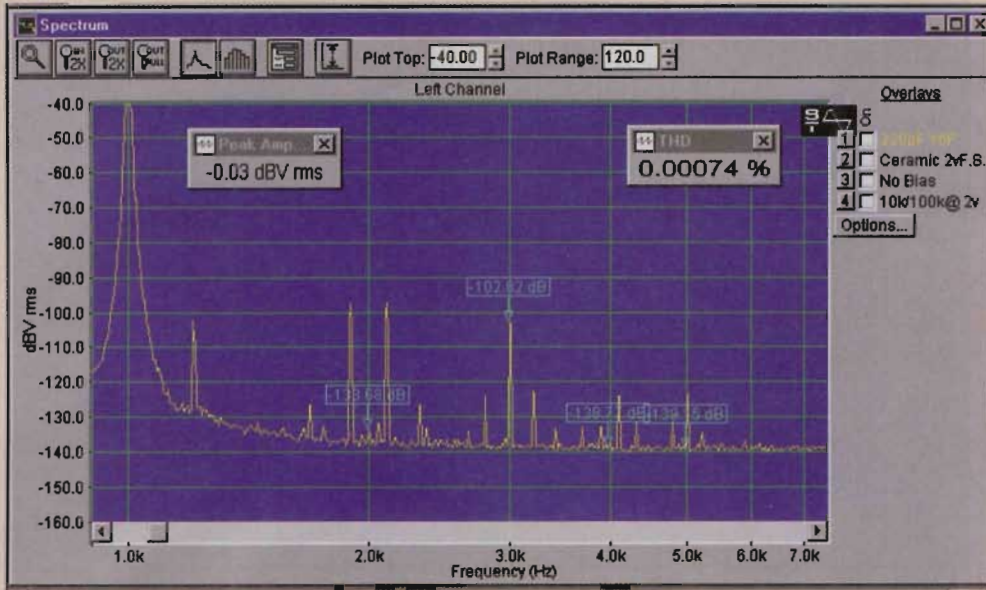


Figure 1: Y5P is a medium 'k' class 2 ceramic. Tested with two signals, 100Hz and 1kHz at 2 volts amplitude, with no bias network, it produces many new intermodulation distortion frequencies.

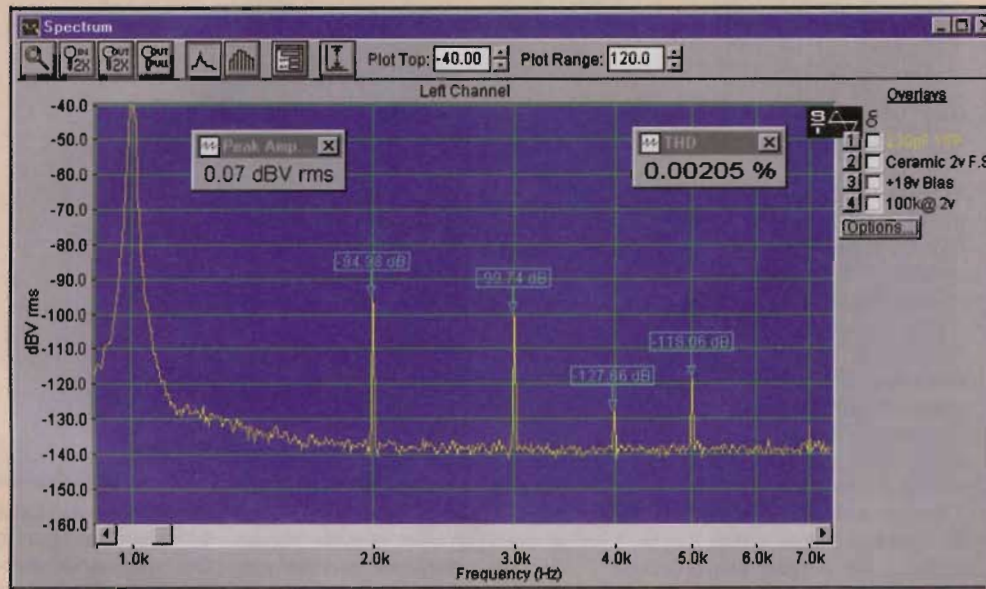


Figure 2: The figure 1 capacitor tested using 1kHz only with 18 volt DC bias. Compared to its 0 volt bias test, second harmonic has increased 23dB, a 14 times distortion increase.

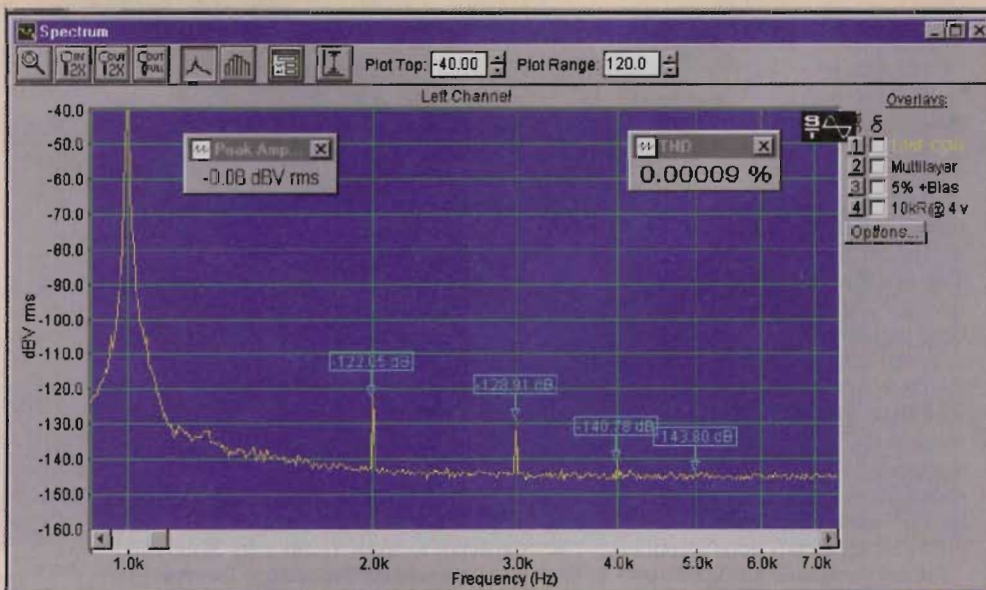
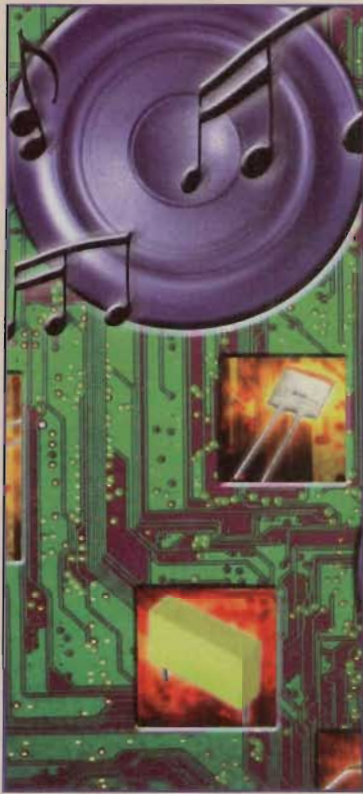


Figure 5: Distortion measurement of a Class 1 ceramic using 100Hz and 1kHz signals at 4 volts and 18 volt DC bias. With no bias this tiny 10nF 50 volt COG multilayer capacitor measured just 0.00006%. Second harmonic was -128.5dB, the other levels remained as shown.



# Capacitor sound 3



## Capacitances of 10nF and smaller.

Figure 1: Y5P is a medium 'k' class 2 ceramic. Tested with two signals, 100Hz and 1kHz at 2 volts amplitude, with no bias network, it produces many new intermodulation distortion frequencies.

Readers of my recent articles have seen that many capacitors do introduce distortions onto a pure sine wave test signal.<sup>1</sup> In some instances this distortion results from the unfavourable loading the capacitor imposes onto its driver circuit and frequently the distortion is generated in the capacitor.

When two or more signals are involved, a distorting capacitor produces a multiplicity of new frequencies. Used in an audio system, this can result in distorted sound. **Fig. 1.** Measurements are now made using a computer soundcard with FFT software, replacing the Pico ADC-100. The chosen software facilitates analysis, by calculating distortion relative to the voltage across the test capacitor. (see box Soundcard FFT Software.)

Many capacitors that distort little when sine wave tested without a DC bias voltage, exhibit much bigger distortions with increasing polarisation. With an 18 volt DC bias, the second harmonic of the capacitor in figure 1, increased by 23dB, but other harmonics hardly changed. **Fig. 2.**

### Why should this be?

As a capacitor design engineer of many years, when I commenced these tests I believed that capacitor distortions would relate directly to the capacitor's measured  $\tan\delta$ . Dielectric absorption does not appear to significantly affect  $\tan\delta$  measurements, so I reasoned it should not greatly affect a capacitor's sound. I certainly was not alone in this belief.

More than 2000 distortion measurements have been made, using test signals from 0.1 volt to 6 volts AC and DC bias from 0 volt to 30 volt. Using a variety of capacitors, purchased for these tests and observing the effect of changing one measurement stimulus at a time, I was able to analyse the different distortions.

Starting in January 2002, these

measurements together with their analysis, occupied many weeks. With a 30 minute warm up, my test equipment performed consistently throughout, producing exceptionally low distortion. I now realise dielectric absorption does influence measured distortions, even if the capacitor measures a low  $\tan\delta$  on a bridge. (See box  $\tan\delta$ /ESR.)

As will be seen later in this series, when a capacitor is used with a significant DC bias, dielectric absorption becomes the dominant distortion producing mechanism. Whether these measurable capacitor distortions become audible or not, depends on the capacitor's location in the circuit. The capacitor voltage levels, any subsequent circuit gain and whether the capacitor is located inside or outside of a negative feedback loop.

### Repetition.

As a result, it became necessary to repeat most of my early single frequency tests, now using two frequencies. Distortion was measured both with and without DC bias voltage applied to the capacitor. To replicate many circuit voltages without over-stressing most capacitors, for this article I standardised on an 18volt DC bias. Apart from Figure 1, the bias network was left in situ and switched to discharge for no bias measurements.

My 1kHz notch filter preamplifier was designed to attenuate 100Hz by some 55dB. A 100Hz test signal, similar in amplitude to the 1kHz signal, can be input without overloading the preamplifier or soundcard.<sup>1</sup>

To apply a DC bias voltage across the test capacitor, a protective 'DC Bias' network must be used. I already had one, built using 100 $\mu$ F and 1 $\mu$ F metallised PET capacitors, used to measure capacitance change with applied DC bias, of capacitances up to 10 $\mu$ F.

When tested with my near perfect 1 $\mu$ F KP test capacitor<sup>2</sup>, this network introduced its own distortions. A new network was required. It was assembled using 11 $\mu$ F and 1 $\mu$ F MKP capacitors with a 100k $\Omega$  charge/discharge resistor. Another 100k $\Omega$  resistor to ground, protects the pre-amplifier input from charge/discharge transients, but restricts measurements to using 10k $\Omega$  and smaller sense resistors. **Fig. 3.**

This new DC Bias network permits accurate distortion measurements with dual 1 kHz/100 Hz test signals up to six volts AC and with up to 50 volt DC bias. It is quickly attached to or removed from my existing test equipment.<sup>1</sup> It is designed to mount in place of the test capacitor, shown in the figure. (see DC Bias Network, **Fig. 4**)

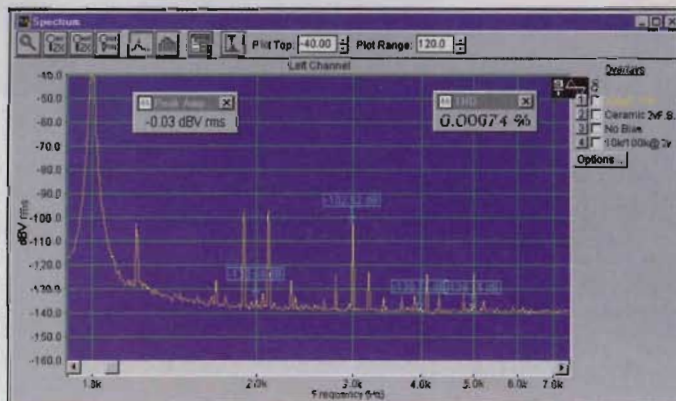




Figure 6: A Class 2 X7R 10nF capacitor from the same maker as figure 5 and tested the same. This test dramatically shows the impact an increase in both  $\tan\delta$  and dielectric absorption have on capacitor distortions.

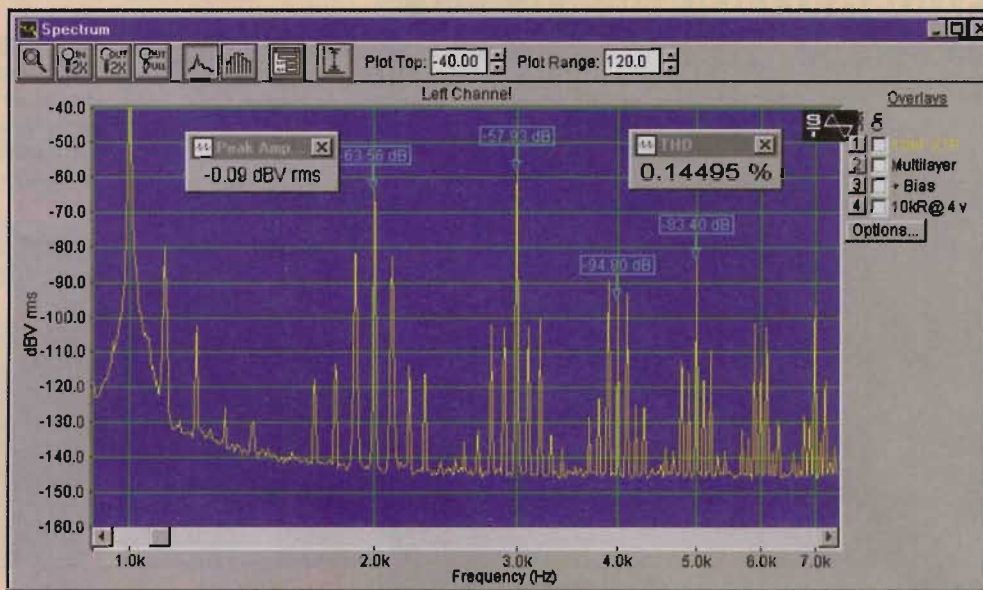


Figure 7: This now discontinued Philips extended foil/Polystyrene 1% axial lead capacitor, with 4 volt signals and 18 volt DC bias, shows negligible distortion. With test signals increased to 6 volt and DC bias to 30 volt second harmonic increased less than 4dB and distortion to 0.00007%. There was no visible intermodulation.

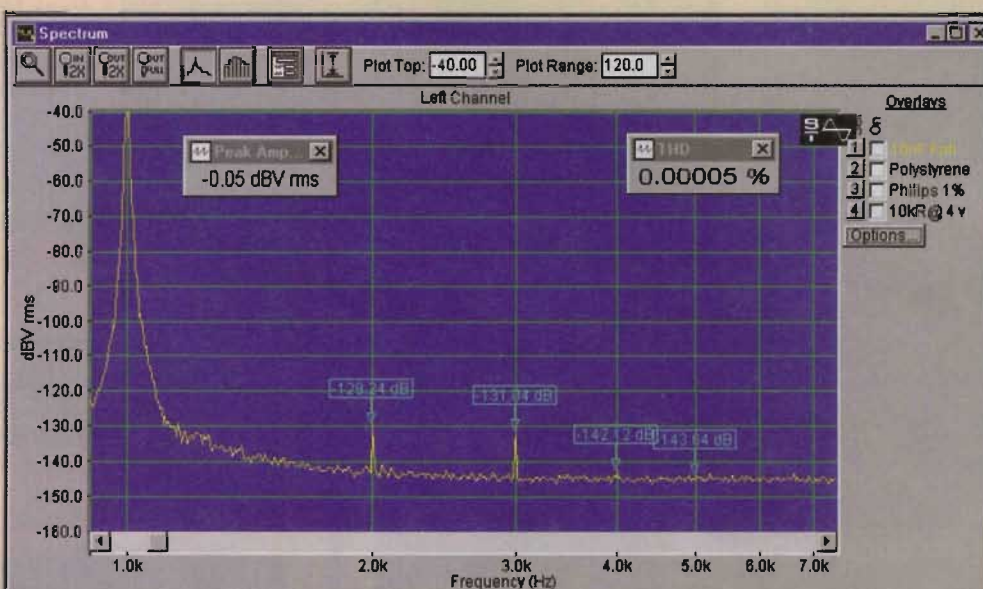
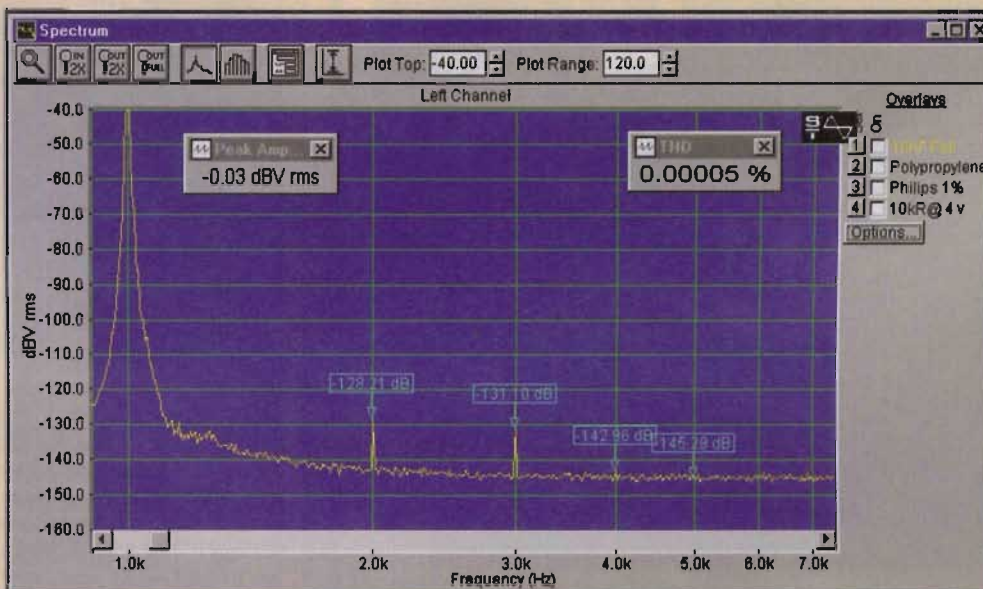


Figure 8: The makers replacement extended foil/Polypropylene shows the same 0.00005% distortion but second harmonic is 1dB worse. With test signals increased to 6 volts and DC bias to 30 volts second harmonic increased just over 5dB, distortion to 0.00008%. Again, no visible intermodulation.





### Capacitor Myths.

Many articles have been written about capacitor behaviour, mostly by authors having little knowledge of capacitor design and construction. As a result, many false capacitor myths have emerged.

I will try to relate some of these myths to facts:-

- All ceramic capacitors distort.
- Dielectric absorption causes smearing and compresses dynamic range.
- Polypropylene is an inefficient material.
- Capacitors are highly inductive at audio frequencies.
- ESR of a capacitor has a fixed value.

### Capacitor production tests.

In manufacture every capacitor is measured for capacitance and  $\tan\delta$ , usually at 1kHz. Capacitance values of 100 $\mu$ F and smaller are measured at 1MHz. Capacitors larger than 1 $\mu$ F are usually measured at 100Hz. (see box  $\tan\delta$ /ESR.) Each capacitor is 'voltage proof' tested to ensure reliable operation at rated voltage. Leakage current or insulation resistance will be measured at the specified time interval or less. To expedite this time consuming measurement, leakage currents/insulation resistance are conservatively stated.

Many other tests will be performed on sample capacitors, to ensure compliance with National periodic 'Type Tests', but I know of no company that routinely tests for harmonic distortion, at realistic circuit voltages. Capacitors are not categorised for distortion, so a distorting capacitor would not be considered defective by its maker. It is the responsibility of the equipment designer to select the correct capacitor for each circuit requirement.

$\tan\delta$  measurement reflects both insulation resistance and series resistive losses. Invariably the LCR meters used include a 'tuned' detector, designed to exclude extraneous frequencies. As will be seen, dielectric absorption affects the second harmonic, so is transparent when measuring  $\tan\delta$ . Fig. 2.

### Dielectric characteristics.

In essence, two major dielectric characteristics exist, polar and non-polar. By polar, I am not referring to an electrolytic capacitor, but how the dielectric responds to voltage stress. This stress relates to the volts per micron gradient across the dielectric, not simply the applied voltage.

Vacuum and air are little affected by voltage stress and solid dielectrics which behave in a similar fashion are termed 'non-polar'. Most solid dielectrics and insulators

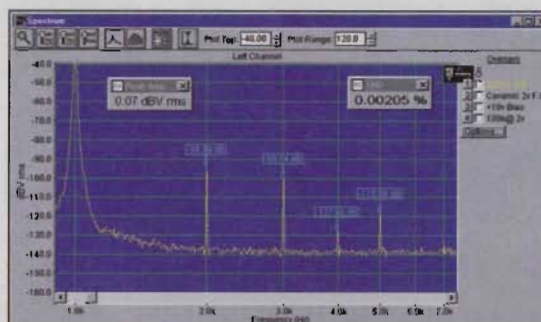


Figure 2: The figure 1 capacitor tested using 1kHz only with 18 volt DC bias. Compared to its 0 volt bias test, second harmonic has increased 23dB, a 14 times distortion increase.

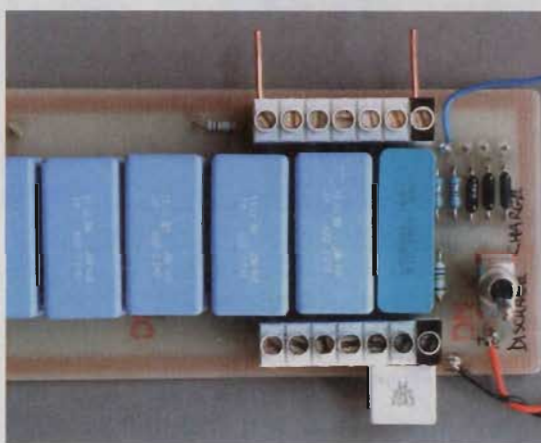


Figure 3: A fly lead connected to the hot AOT resistor terminal, a duplicate set of source resistors and five 2.2 $\mu$ F MKP blocking capacitors, couple the 1kHz test signal. The test capacitor output is fed to the pre-amplifier via a 1 $\mu$ F capacitor. A current limited 100Hz test signal may be input to the top left terminal, DC bias to bottom right.

## Soundcard FFT Software

Measurements for my earlier articles used a Pico ADC-100. Many readers may wish to use a soundcard instead. A modern low cost PCI card with FFT software can provide increased dynamic range, measuring smaller distortions using my instruments, than is possible with the ADC-100. I now use the Spectra 'Plus232' software under Windows 98SE with a Soundblaster Live 1024 card, for all measurements.

With 'CoolEdit', the audio manipulation software already on my hard disc, I did try using it to measure capacitor distortions. Both 'CoolEdit' and the Pico ADC-100 software display distortion spectra but don't calculate percentage distortion. Tired of making a great many repetitive calculations, I searched internet for a better solution.

I downloaded some twenty FFT packages for evaluation. On reading their help files, many were obviously of little use. A small number looked promising, because they provided a dB

scaled display and calculated distortion percentages. However few packages promised any facility to calibrate and control the soundcard gain settings.

I decided the best choice was the Spectra 'Plus232' software. Ref.6 I calibrated its input level using a known 1 volt signal. This calibration was accurately maintained from day to day. Having established a measurement set-up, it was saved as a 'config' file for re-use.

It also accepts a correction file, intended to compensate for microphone errors. Having carefully measured the output of my notch filter/pre-amp by frequency using a 1 volt test signal, I wrote a correction file to restore the much attenuated test fundamental back to level and correct for pre-amplifier gain errors. The software then automatically displays percent harmonic distortion, on screen. Fig. 12

I quickly produced other files, from 0.1 volt test level to 6 volts, by simply

adding or subtracting the appropriate dB levels to the 1 volt file values. see Table. Spectra 'Plus232' can measure in real time, without first saving to disc. It can be used to cover the maximum frequency span of your soundcard, or as shown to measure over your selected frequency band.

Spectra 'Plus232' software was used for all capacitor distortion measurements, more than 2000 in all taken over several weeks, commencing with those for this article. Should you have only an older ISA soundcard, some software may not work. One that will, is FFT.EXE, a very simple, no-frills, DOS program by Henk Thomassen. This can be found on the internet and also on the Elektor 96-97 software CD-ROM.

Users having a modern PCI soundcard will find a very large variety of programs, often available as freeware, on the internet. One site that links to some of the better packages is [www.pcvtech.com/links/index.htm](http://www.pcvtech.com/links/index.htm).



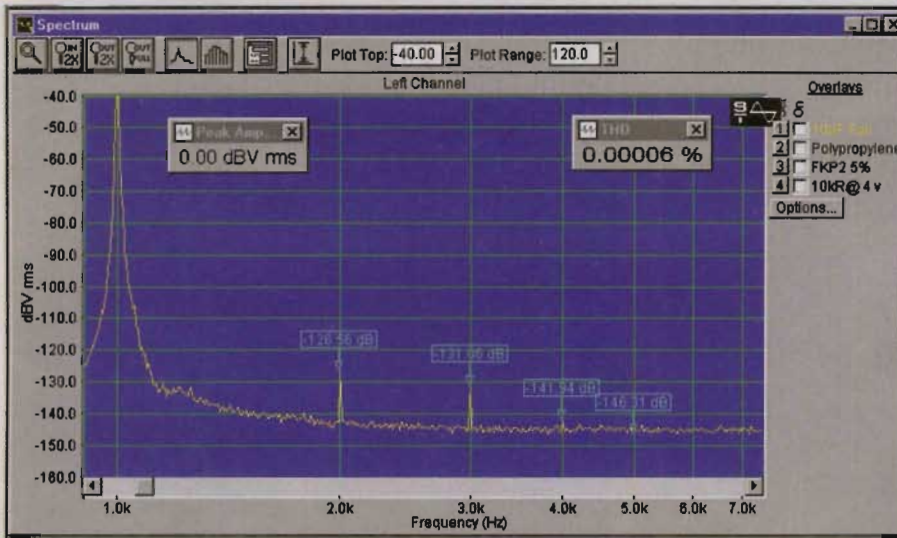


Figure 9: The small Wima FKP2 foil/Polypropylene capacitor shows similar performance except for 2dB increased second harmonic. Distortion just 0.00008% with 6 volts stimulus and 30 volts DC bias.

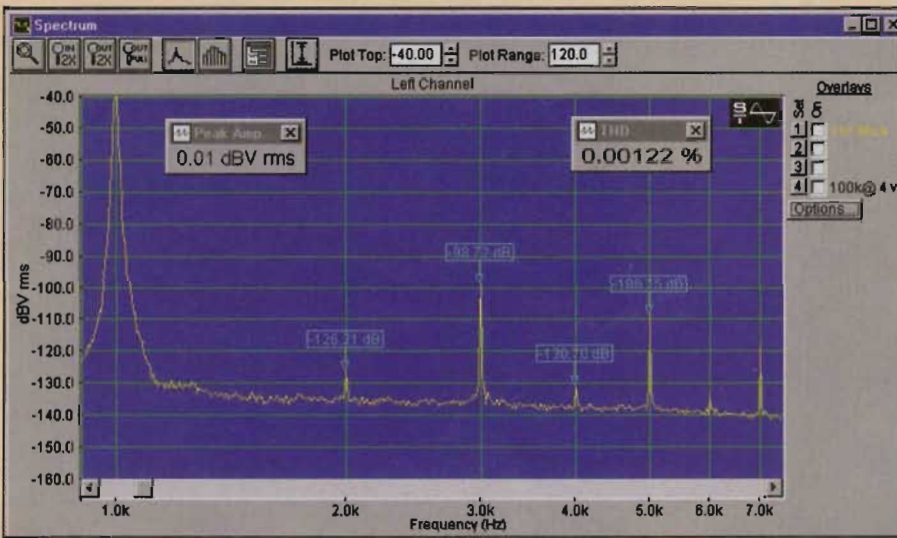


Figure 10: Despite cleaning and re-tinning its oxidised lead out wires, this 1nF Mica capacitor, tested using 1kHz only at 4 volts and no bias, clearly has an internal non-ohmic connection problem.

Figure 11: Tested with no bias, this 0.1µF MKS2 metallised PET capacitor measured 0.00016% with clearly visible intermodulation products. With 18 volts DC bias, the second harmonic increased dramatically, from -119.0dB to -92.9dB and harmonic distortion to 0.00225%.

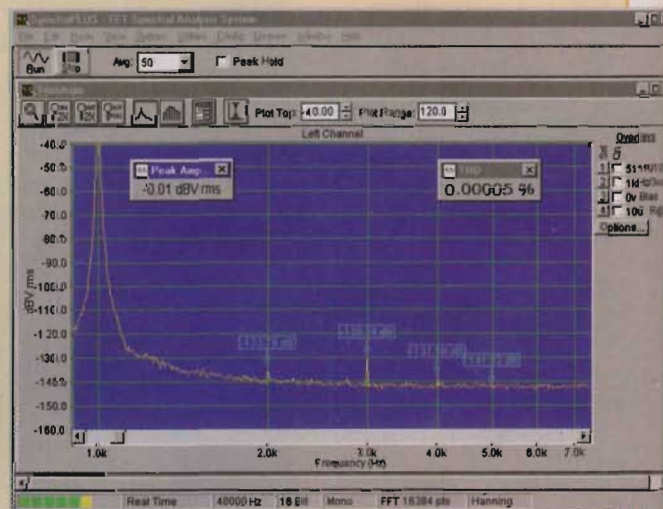
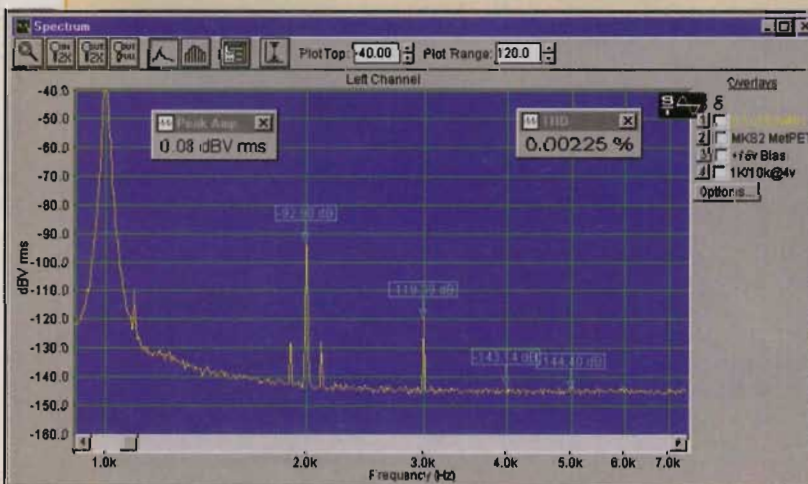
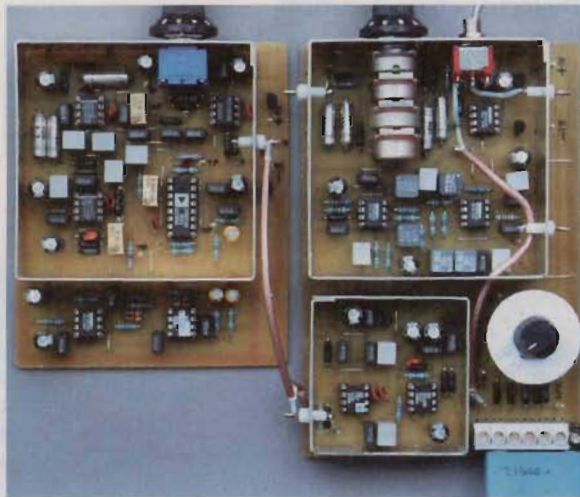


Figure 12: The Plus232 software shows a green then yellow signal strength meter, bottom left, changing dramatically to red at the soundcard overload level. My 'standard' measurement settings can be seen. Loaded with a 511Ω resistor, all harmonics are well below 0.5 ppm distortion.

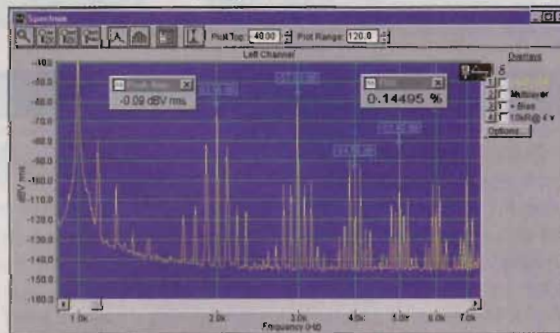


**Figure 4:** Low distortion test equipment measuring distortion of a capacitor with AC test signal, as described in my last two articles. To measure capacitors with DC bias, the network of Figure 3 with test capacitor attached, replaces the test capacitor shown bottom right.



**Figure 5:** Distortion measurement of a Class 1 ceramic using 100Hz and 1kHz signals at 4 volts and 18 volt DC bias. With no bias this tiny 10nF 50 volt C0G multilayer capacitor measured just 0.00006%. Second harmonic was -128.5dB, the other levels remained as shown.

**Figure 6:** A Class 2 X7R 10nF capacitor from the same maker as figure 5 and tested the same. This test dramatically shows the impact an increase in both tan $\delta$  and dielectric absorption have on capacitor distortions.



are affected, increasing roughly in line with their 'k' value. This 'k' value is the increase in measured capacitance when the chosen dielectric is used to displace air.

Under voltage stress, electrons are attracted towards the positive electrode. The electron spin orbits become distorted, creating stress and a so-called 'space charge' within the dielectric. This produces heat in the dielectric with power loss, called dielectric loss, together with second harmonic distortion.

Non-polar dielectrics exhibit very small dielectric loss. Polar dielectrics are lossier and take longer for the dielectric to return to its original uncharged state. Polar dielectrics produce easily measured 'dielectric absorption' effects, especially apparent in thin dielectrics

Dielectric absorption is measured by fully charging the capacitor for several minutes then briefly discharging into a low value resistor. After a rest period, any 'recovered' voltage is measured. The ratio of recovered voltage to charge voltage is called dielectric absorption.

**Ceramic capacitors.**

'Ceramic' covers an extremely wide range of dielectrics, sub-divided as Class 1 (non-polar) or Class 2 (polar) according to the materials used to make up the ceramic. Class 1 ceramics do not use Barium Titanate and so have a low 'k' value. The best known is C0G. With its controlled temperature coefficient of zero  $\pm$  30 ppm, it was originally called NP0 by the Erie Corporation. It is non-polar and has a small dielectric absorption coefficient. From my tests, it has almost no measurable harmonic distortion. **Fig. 5.**

C0G ceramic provides the most stable capacitance value, over long time periods and temperature excursions, of all easily obtained capacitor dielectrics. It is frequently used as a capacitance transfer standard in calibration laboratories and yet as a small disc capacitor, it costs only pennies. Assembled as a multilayer, it can provide capacitances of 100nF and above, rated for 50 volts working, and can achieve higher working voltages for smaller capacitances.

Other Class 1 ceramics, sometimes called 'low k', provide increased capacitance within a controlled temperature coefficient, e.g. P100, N750 etc. in ppm. These also are non-polar and exhibit almost no measurable dielectric absorption. I have tested up to N750, sometimes called U2J, and found very low distortion.

Class 2 ceramics do include Barium Titanate. It produces a very high dielectric constant, with 'k' values ranging from a few hundred to several thousands. Class 2 ceramic is strongly polar and its capacitance varies with applied voltage and temperature. It exhibits an easily measured

**DC Bias Network**

Two DC blocking capacitors are needed, one to couple the signal to the test capacitor and the second to couple the test capacitor voltage into the pre-amplifier input. To minimise test signal loss, that capacitor should be ten times the value of the capacitor being tested. To not introduce distortion it should be of much higher voltage rating than the DC bias and the same or better quality, as the best capacitor to be tested. I used five 2.2 $\mu$ F 250 volt MKP from BC Components (Philips), type 378

capacitors connected in parallel. To couple the test capacitor voltage to the high impedance preamplifier input, a smaller value can be used. For this a 1 $\mu$ F 250 volt version of the MKP capacitor would be fine. I already had a distortion tested sample of the Epcos (Siemens) equivalent, so I used that instead. Source impedance resistors, as used in the buffer amplifier, are selected and connected to the AOT 'hot' pin using a short fly lead. Two 100k $\Omega$  charge/discharge resistors and a toggle

switch, completed the bias network. **Fig. 3.** All were mounted on a single sided PCB size 110 x 55 mm. For convenient interconnections, I mounted two lengths of the terminal strip, one on either side of the buffer. **Fig. 13** To avoid overloading the soundcard input, the 100Hz/1kHz connections to the bias network should be completed before connecting the pre-amp output to the sound card.



Tanδ/ESR

Tanδ is used to describe capacitor quality. A textbook perfect capacitor has a phase angle of 90°, a phase angle deviation of 0°, a Tanδ of zero. Using a 6425 precision LCR meter, Tanδ of a most nearly perfect capacitor at 1kHz measured just 0.00005, a phase angle deviation less than 0.003°. These measurements were made on a Philips 10nF 1%, axial lead, extended foil and Polystyrene capacitor. Fig. 7

Some of the resistive losses which contribute to Tanδ are due to lead out wires and metal electrodes, so are relatively constant. Tanδ then increases with frequency. At 10kHz, Tanδ for this capacitor was measured at 0.00015 and just 0.0005 at 100kHz.

In past years capacitor quality was sometimes described as a 'Q' value, the reciprocal of Tanδ. 'Q' for the above capacitor was 20,000 at 1kHz, 6,666 at 10kHz and 2,000 at 100kHz.

Tanδ is measured using phase sensitive detectors, either by measuring the

capacitor's impedance and phase angle, or the capacitor's resistive and reactive component vectors.

In which case,

$$\text{Tan}\delta = \frac{\text{resistive vector}}{\text{reactive vector.}}$$

This resistive vector is called ESR.

$$\text{ESR} = \frac{\text{Tan}\delta}{\text{reactive vector.}}$$

Obviously ESR must vary with frequency. At low frequencies, ESR reduces with frequency, up to the self-resonance of the capacitor. At self-resonance, the capacitive and inductive reactances have equal and opposite values, so cancel out. The capacitor's ESR is then equal to its measured impedance. For that frequency only, it

can be measured using a signal generator and voltmeter. At higher frequencies, ESR usually increases. The abbreviation TSR, for True Series Resistance, is often used by capacitor engineers to describe this minimal value of ESR.

The LCR meter readings for ESR of the above capacitor, recorded 0.8Ω for 1kHz, 0.26Ω for 10kHz and 0.08Ω for 100kHz.

Self-inductance reduces the capacitor's measured reactance value. This means a capacitor's self inductance actually increases its measured capacitance value.

A fuller description of Tanδ together with a proven measurement circuit was included in my articles describing the construction of an in-circuit meter.<sup>7</sup> This meter was custom designed to identify good or bad PCB mounted electrolytic capacitors by measuring their Tanδ while in-circuit.

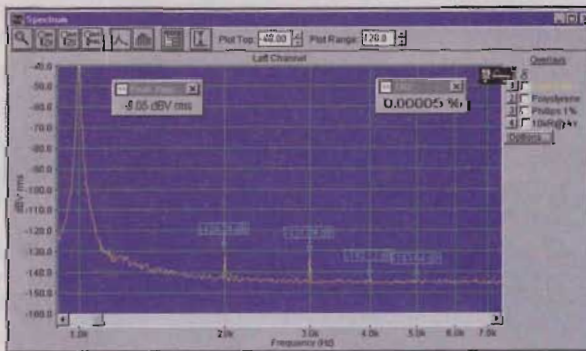
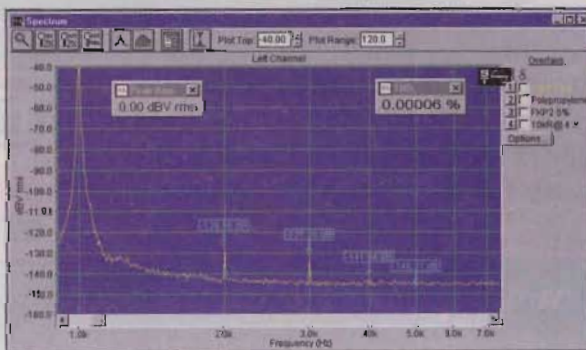
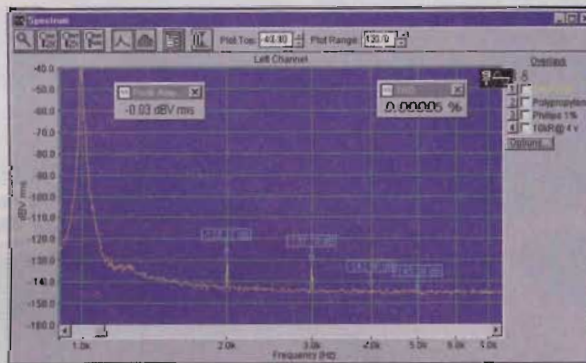


Figure 7: This now discontinued Philips extended foil/Polystyrene 1% axial lead capacitor, with 4 volt signals and 18 volt DC bias, shows negligible distortion. With test signals increased to 6 volt and DC bias to 30 volt second harmonic increased less than 4dB and distortion to 0.00007%. There was no visible intermodulation.

Figure 8: The makers replacement extended foil/Polypropylene shows the same 0.00005% distortion but second harmonic is 1dB worse. With test signals increased to 6 volts and DC bias to 30 volts second harmonic increased just over 5dB, distortion to 0.00008%. Again, no visible intermodulation.



dielectric absorption, which increases with 'k' value.

Popular Class 2 ceramics include the X7R, W5R, BX capacitor grades and the exceptionally high 'k' Z5U. These produce extremely large measured distortions. Fig. 6.

Film capacitors.

Film dielectrics have smaller 'k' values, ranging from 2.2 for Polypropylene (PP) to 3.3 for Polyethylene Terephthalate (PET).<sup>3</sup> More significant than 'k' value is just how thin the film can be produced and used to assemble capacitors.

Perhaps the best of the easily obtained plastic film dielectrics, Polystyrene is now becoming less popular. It has an N150 temperature coefficient, a very small tanδ and the smallest dielectric absorption coefficient of all film materials. It softens around 85°C and cannot be metallised or used thinner than 4 microns, to manufacture capacitors. Fig. 7.

For years it was wound with solderable soft metal electrodes, producing vast quantities of 1% tolerance, high quality capacitors, with values up to several μF.

All other popular film dielectrics can be metallised. They can be used to produce small, low cost, metallised film capacitors having a limited current handling ability. Alternately, using the superior foil and film assembly to produce larger and higher cost capacitors for the same value and voltage. Foil and film capacitors survive larger

Figure 9: The small Wima FKP2 foil/Polypropylene capacitor shows similar performance except for 2dB increased second harmonic. Distortion just 0.00008% with 6 volts stimulus and 30 volts DC bias.



Table 1

Correction Table for 1 volt at 1kHz distortion measurements.

Frequency (Hz)	Value (dB)	Frequency (Hz)	Value dB	Frequency (Hz)	Value dB
100	-14.0	1005	-24.45	2100	40.0
200	-3.2	1010	-24.0	2200	40.0
300	3.3	1050	-10.0	2500	39.8
400	6.0	1100	8.2	3000	39.65
500	8.0	1200	16.2	4000	39.9
600	9.0	1300	21.4	5000	40.2
700	9.0	1400	25.6	6000	40.3
800	7.6	1500	29.2	7000	40.2
900	3.5	1600	32.4	8000	39.6
950	-10.0	1700	35.2	9000	38.7
990	-24.0	1800	37.25	10000	37.2
995	-24.45	1900	38.8	11000	36.0
1000	-24.45	2000	39.6		

AC currents, than metallised film types.

Metallised film capacitors rely on 'self-healing' to 'clear' minor insulation faults, so can be assembled using very thin films, their metallised electrodes adding almost no thickness. Capacitance is inversely proportional to dielectric thickness, so they provide a large capacitance in a small package. Conversely, foil and film capacitors cannot self-heal, so they must be made using film of sufficient thickness to withstand the required voltage without self-healing and being wound with metal foil electrodes.

PET has very high tensile and voltage strengths and is easily metallised. Film thinner than one micron can be used in 50 volt capacitors. It is polar with 0.5% dielectric absorption and a relatively high 0.5% tand. Capacitance and tand are strongly temperature and frequency dependant and with up to 3% capacitance change in two years, it has poor long term stability. A metallised PET capacitor rated for 100 volt may use film perhaps one micron thick. A foil and film PET capacitor might be made using five micron thick film. With five times the volts/micron stress, we measure more distortion with the metallised film type.

In contrast, non-polar PP, has a very small dielectric absorption of 0.01% and a low tand of 0.03%. It has less tensile strength and is much more difficult to metallise. Assembling capacitors using PP film thinner than 4 micron is difficult, so PP is best suited to producing higher voltage capacitors. With dielectric losses only slightly higher than COG ceramic or Polystyrene and usable to 105°C, PP can provide large capacitance high voltage capacitors, suited for use on AC or DC. Since its introduction more than 30 years ago, it has produced the most reliable capacitors used in the high stress line-scan circuits of domestic TV receivers. PP is one of the most efficient, low loss dielectrics.

### Capacitor connections.

For the best, undistorted sound, dielectric choice is obviously all-important. But using the best dielectric materials does not guarantee a non-distorting capacitor. A poor dielectric principally influences the levels of the second and even harmonics produced by the capacitor. An internal non-ohmic connection in the capacitor however, introduces significant levels of odd harmonics, the third having the biggest amplitude.<sup>4</sup>

Disc ceramics use solder connections to a sintered, usually silver, electrode. Multilayer ceramics mostly use precious metal sintered end termination, with soldered

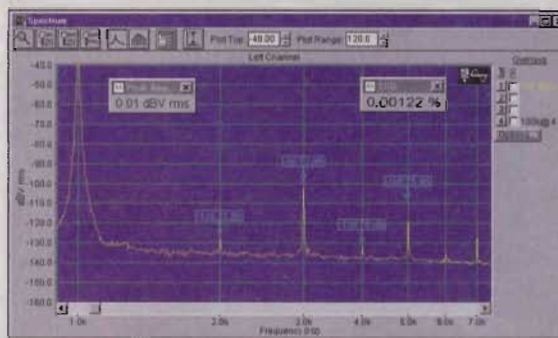


Figure 10: Despite cleaning and re-tinning its oxidised lead out wires, this 1nF Mica capacitor, tested using 1kHz only at 4 volts and no bias, clearly has an internal non-ohmic connection problem.

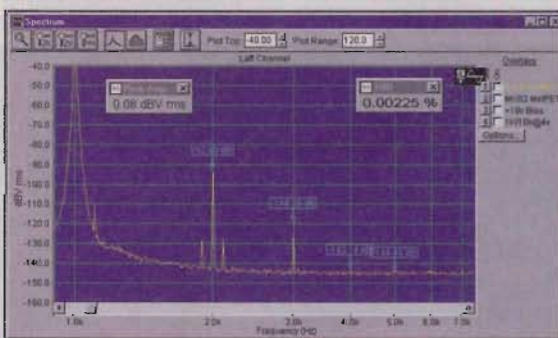


Figure 11: Tested with no bias, this 0.1mF MKS2 metallised PET capacitor measured 0.00225% with clearly visible intermodulation products. With 18 volts DC bias, the second harmonic increased dramatically, from -119.0dB to -92.9dB and harmonic distortion to 0.00225%.

wire leads. I have not found ceramic capacitors with non-ohmic end connections. All Class 1 ceramics I measured, have produced negligible and mostly second harmonic, distortions.

From research carried out in Sweden by the Ericsson Company, a non-ohmic connection can exist in film capacitors. All metallised film and many foil and film capacitors use a 'Schoop' metal spray end connection to connect the capacitor electrodes to the lead-out wires.

I have measured many metallised film capacitors having very large third harmonic levels, frequently as much as +20dB higher than others in the same batch. I have not found this problem when foil electrodes are used with the same dielectric.

To avoid any possibility of a non-ohmic end connection we could use a solderable, soft metal foil electrode and solder it directly to the lead out wires. This is exactly the time proven assembly used by a large maker of extended foil/Polystyrene (PS) capacitors. It produces a near perfect, non-distorting, capacitor. Fig. 7.

Unfortunately, few manufacturers still make PS capacitors and many have changed their production over to extended foil/PP, retaining the soldered end connections.



Polystyrene dielectric has almost unequalled electrical properties but softens at low temperatures, so cannot be flow soldered into a circuit board. It is also attacked by many solvents, so boards with unprotected capacitors are not easily cleaned.

### Self Inductance.

Each electrode turn of an extended foil or metallised film capacitor, is short circuited to every other turn, so contributes almost no self-inductance. Self-inductance of a capacitor body is then less than its equivalent length of lead wire. These capacitors have almost no self-inductance, apart from the 7nH per cm of the lead wires used to connect them into circuit.

By way of interest, I measured the resonant frequency of a 10nF 'Tombstone' capacitor.<sup>5</sup> A vertical mounting, extended foil, axial wound capacitor. This construction has a small footprint but increased inductance due to its one

extended lead out wire. The self-resonance frequency was above 10MHz. At audio frequencies, such small self-inductances are clearly unimportant.

### Low distortion choice.

For the lowest distortion I still prefer PS, however from my measurements, it proved almost impossible to distinguish between an extended foil/PS and a similarly made foil/PP capacitor. Apart from small increases in second harmonic, measured for the PP versions. Both types are easily available from mainstream distributors in values up to 10nF. **Fig. 7, Fig. 8.**

For low distortion capacitors up to 10nF, my personal choices would be C0G ceramic, perhaps also including discs up to N750, extended foil/PS or extended foil/PP, with the lead out wires soldered to the electrodes. **Fig. 9.**

### Alternative capacitors.

Perhaps because of size, price, temperature range or voltage, the above small selection is not suitable. Stacked Mica is still available, but from my tests can be variable. I have some which are at least thirty years old with almost no measurable distortion. However, a small batch of 1nF, purchased specially for these measurements, distorted badly. One sample was even unstable, showing significant and variable third harmonic. **Fig. 10.**

I have measured very low distortions with Wima FKC2 foil and Polycarbonate capacitors. Bayer has discontinued production of Makrolon Polycarbonate film, so FKC2 capacitor production may cease. No doubt because of the thicker PET film used, I have measured surprisingly low distortion when testing Wima 10nF 100 volt FKS2 foil and PET capacitors. Results were almost as good as the FKP2 foil and PP of Figure 8. Tested with 30 volt DC bias, second harmonic distortion was only 2dB worse than for the PP capacitor. Unfortunately, this FKS2 style is not available in bigger values.

Having measured several hundred metallised PET capacitors, I have found many with extremely low distortions when measured without DC bias. I have also found far too many showing very bad distortions, with and without DC bias. **Fig. 11.**

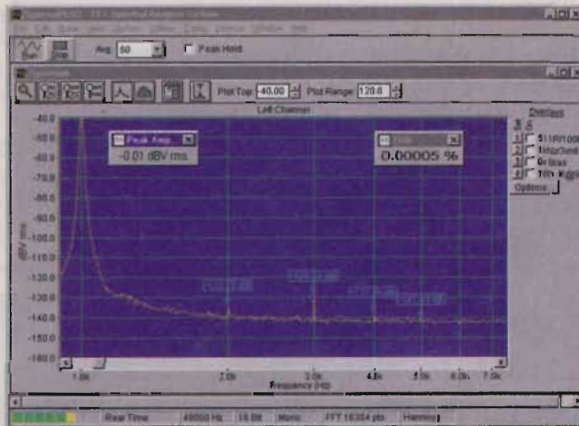
For capacitances up to 10nF, low distortion, low cost capacitors are easily available, so I would avoid using metallised PET capacitors. For capacitance values above 10nF, the near perfect C0G, foil/PS and foil/PP types are not easily available. Our best options for capacitance values from 10nF to 1µF will form the subject of my next article.

Two further articles will then extend our distortion measurements to 100µF electrolytic, exploring our best options for these values. ■

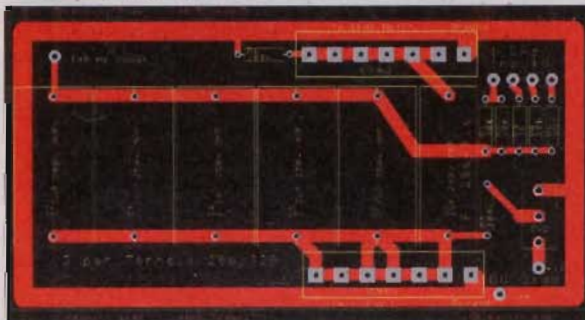
### References.

- 1 Capacitor Sound parts 1&2 C. BatemanEW July/September 2002.
- 2 BC Components 0.47+0.47µF 250 volt type 376 KP. Farnell part 577-881
- 3 Film Capacitors 2000. Evox Rifa AB. Kalmar. Sweden.
- 4 Harmonic testing pinpoints passive component flaws. V. Peterson & Per-Olof Harris. Electronics July 11, 1966.
- 5 High-frequency impedance meter. C. Bateman. EW January 2001.
- 6 Spectra 232Plus FFT software. www.telebyte.com/pioneer
- 7 Check C's in situ. C. Bateman. EW May/June 1999

**Figure 12:** The Plus232 software shows a green then yellow signal strength meter, bottom left, changing dramatically to red at the soundcard overload level. My 'standard' measurement settings can be seen. Loaded with a 511Ω resistor, all harmonics are well below 0.5 ppm distortion.



**Figure 13:** The 110 x 55 mm single sided PCB used to assemble Figure 3, the 1kHz DC blocking buffer network.



## Technical Support

Interested readers are free to build a system for personal use or educational use in schools and colleges. Commercial users or replicators should first contact the author.

A professionally produced set of three printed circuit boards is available for the 1kHz low distortion signal generator, the 1kHz low output impedance buffer amplifier/notch filter/pre-amplifier and the 1kHz DC bias buffer network. This set of three boards provides a complete 'with DC bias, single frequency, distortion test system'.

Supplied with component parts lists and assembly/usage notes, these single sided FR4 boards have solder resist and component legends. The set of three boards costs £32.50.

Post/packing to UK address £2.50.

Post/packing to EU address £3.50, rest of world £5.00.

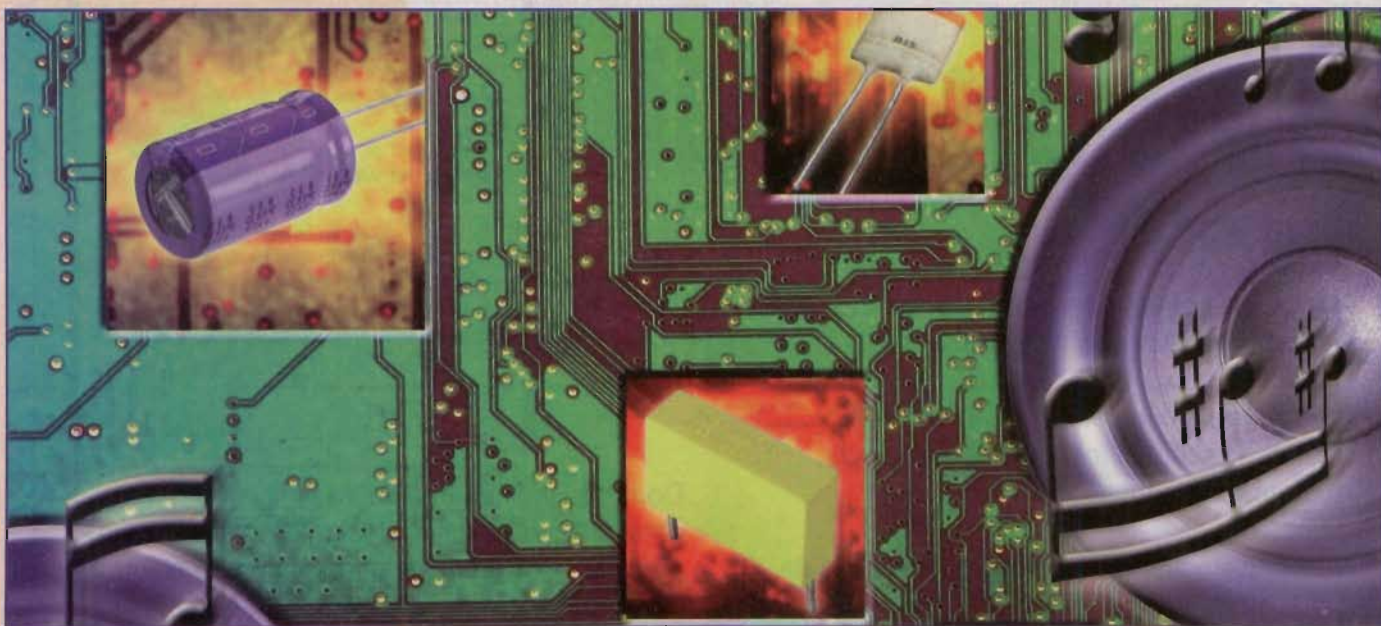
Please send Postal Orders or Cheques, for pounds sterling only, to C. Bateman. 'Nimrod' New Road. ACLE. Norfolk NR13 3BD.



capacitor.

Some of the illustrations in last month's article were accidentally reduced too much, resulting in some of the text bordering on being illegible. Those diagrams are repeated over the next pages in larger form. Apologies.





# Capacitor sound 4

**This month, Cyril concentrates on the difficult area of 100nF to 1µF, which usually for size and cost reasons means using metallised PET products**

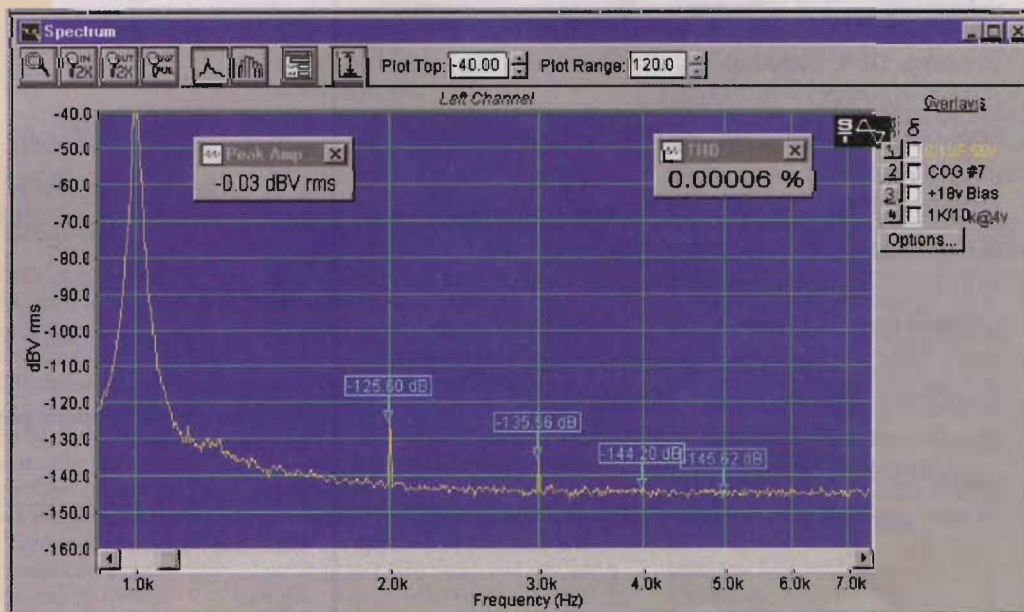
**R**eaders of my previous articles will have seen that many capacitors do introduce distortions onto a pure sine wave test signal. In some instances distortion results from the loading the capacitor imposes onto its driver. In others, the capacitor generates the distortion within itself.<sup>1</sup>

Capacitors are not categorised for distortion in manufacture, so a distorting capacitor would not be accepted as reject by its maker. Using my easily replicated test method, capacitor distortions can now be measured, surpassing speculation. Equipment designers can now select capacitors for each circuit requirement.

For capacitances of 10nF and smaller, the safe solution is to use COG ceramic or extended foil/film capacitors. Made with Polystyrene or Polypropylene dielectrics and with leadwires soldered or welded directly to the extended foil electrodes. Avoiding altogether capacitors made with metallised film dielectrics.

These idealised choices minimise all measurable distortion products. While this presents a counsel of perfection, as an engineer I believe prior knowledge of the best and worst extremes should form part of any compromise.

Such near ideal capacitors are not easily



*Figure 1: Distortion measurement of a 100nF 50 volt COG ceramic, using 100Hz and 1kHz signals at 4 volts with 18 volt DC bias. With no bias this multilayer capacitor measured just 0.00004%. Second harmonic was -131.7dB, other harmonics remained as shown.*



available in acceptable sizes or costs for higher capacitance values. Finding suitable low distortion 0.1 $\mu$ F and 1 $\mu$ F capacitors proved almost impossible. High 'k' BX, X7R, W5R and Z5U capacitors produce far too much distortion for our needs.<sup>1</sup>

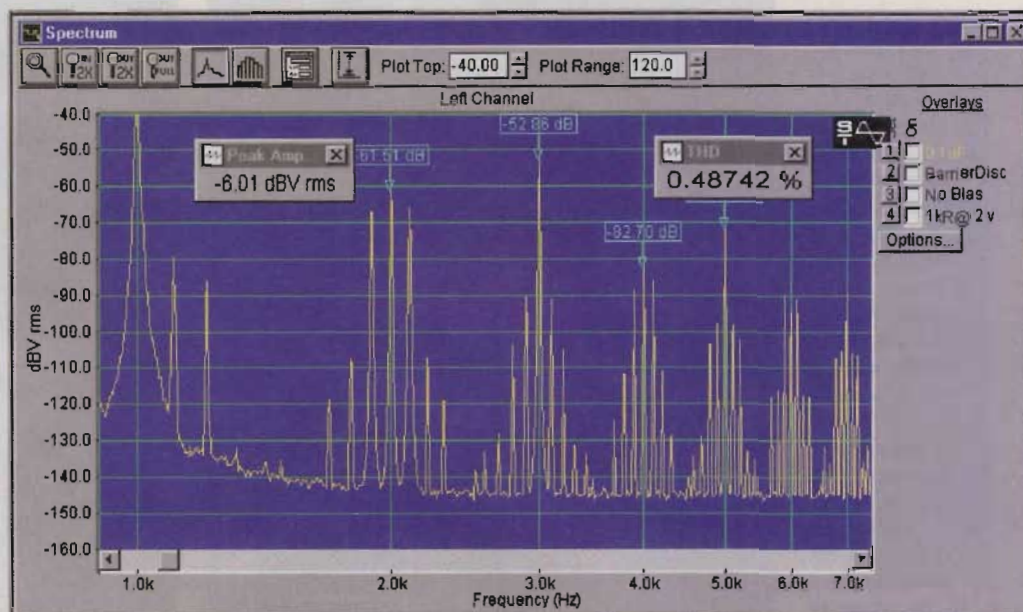
Multi-layer ceramics of 100nF 50 volt manufactured in C0G, produce little distortion, with and without DC bias, but are not easily available in small quantities. **Fig. 1**

### The worst capacitor?

A 100nF ceramic disc capacitor is still available. Having the thinnest possible high-k dielectric it provides the worst possible distortion. Despite this, a number of papers found on the internet choose to use this style on which to base their ceramic capacitor measurements and opinions.<sup>2</sup>

Originally called a 'transcap', it pre-dated all low cost 0.1 $\mu$ F film capacitors by many years. It was developed as the smallest, lowest possible cost capacitor, used in pocket transistor AM radios.

A conventional high 'k' ceramic, re-sintered in a reducing atmosphere, becomes a semi-conducting disc measuring a few Ohms resistance. The outer few surface molecules are re-oxidised when the electrode silver is fired in air, to become the dielectric. If sectioned, you will find a black disc, apparently made from charcoal. Using a high power microscope, you may just see an extremely thin, much lighter coloured dielectric layer covering the outer surfaces.<sup>3</sup>



Such devices have no place in any audio system. So take care if offered a small ceramic disc, having significantly greater capacitance than found in conventional disc capacitors.<sup>4</sup> **Fig. 2**

### Electrolytics

Tantalum or aluminium electrolytic capacitors are available in these values and form the subject of my next article. Meanwhile we will investigate the options available in film capacitors.

Very low distortion foil and film, Polypropylene (PP) and Polyethylene terephthalate (PET) capacitors are available but are large and usually expensive. The lowest

cost, smallest size capacitors, are made with metallised PET.

### Metallised PET capacitors

In the drive, some thirty years ago, to size and cost reduce the 0.1 $\mu$ F capacitor, two problems had to be addressed:

1) First was to produce satisfactory quality, extremely thin metallised PET. In 1978, the Dupont 'Mylar'® capacitor film became available at a thickness of 1.5 microns, some 20 times thinner than human hair.

2) The second was to develop low labour cost methods to wind small capacitor elements. For capacitor makers this was difficult because of the high cost and large numbers of

**Figure 2: The worst distortion of more than 2000 capacitor measurements. The test voltage had to be reduced to two volts AC with no DC bias, to avoid harmonics overloading my soundcard.**

## Metallised film dielectrics

All common film capacitor dielectrics, other than Polystyrene, can be metallised, to produce a negligibly thick electrode. This metallised coating, usually aluminium, is produced by evaporating metal ingots inside a vacuum chamber. The film is stretched taut and passed through the chamber at controlled speed. To prevent overheating, the film passes over refrigerated rollers.

The metallised coating is so thin, it is transparent. Thickness is monitored by measuring resistance, typically a few Ohms per square, of the metallised surface.

PET and PPS films are easily metallised and provide good adhesion to an evaporated aluminium coating. Untreated Polypropylene has a smooth, waxy surface, which inhibits adhesion.

Various pre-treatments have been applied to PP to improve electrode adhesion. These include mechanical roughening and exposure to high voltage ionisation fields. However, a

metallised electrode is often applied to a higher resistance value, i.e. thinner, onto PP than other films.

Contact to the metallised electrode is made by spraying minute metal particles, evaporated inside a high temperature spray gun, onto each end of the capacitor winding. This is known as a 'Schoop' connection. The volume of air needed to propel the metal particles ensures the film surface is only exposed to relatively cool metal and so does not melt.

This 'schoop' metal spray end connection is also used to manufacture some makes of foil and film capacitors and those with double-sided metallised carrier film electrodes. The conductive end spray, short circuits together all turns of a wound capacitor, ensuring minimal self-inductance.

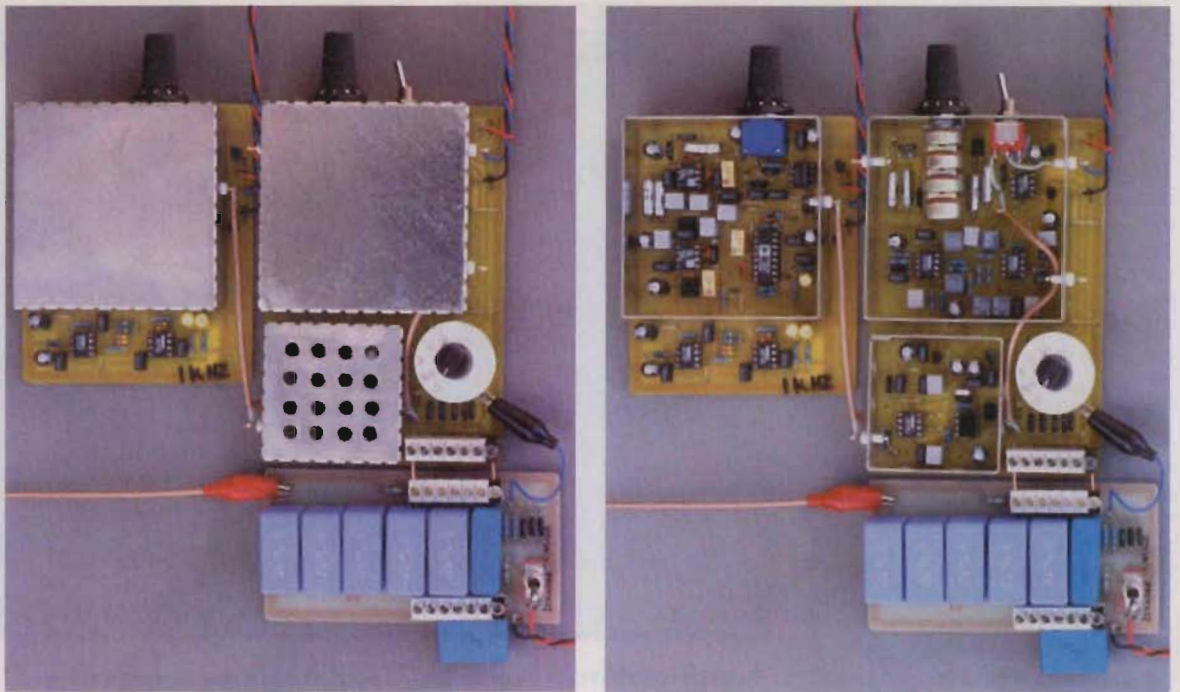
When sufficient 'end spray' thickness has been applied, the capacitor leadwires are attached, usually by soldering or electrical

resistance 'welding.' Properly applied this 'schoop' end spray provides a good connection to the electrodes, able to carry significant current. The extremely thin metallised film electrodes obviously cannot handle high currents. When overloaded, visible electrode 'edge burning' occurs, ultimately leading to an open circuit capacitor.

The resistance of the metallised electrode combined with aluminium's temperature coefficient of 0.0039, results in a non-linear resistance. This may at least partially explain some of the larger third harmonic distortions. One simple indicator of the current carrying ability of the 'schoop' end connection into the electrodes used, can be seen in the peak current ratings claimed for the capacitor. For example a 10nF metallised PET capacitor might be rated for 30v/ $\mu$ sec, foil and PET has a much higher current carrying ability, being rated as high as 1000v/ $\mu$ sec.



Figure 3: Finalised measurement system using two test signals, 100Hz and 1kHz, to measure capacitor intermodulation and harmonic distortion, with and without DC bias voltage. The capacitor under test is mounted directly onto the DC bias buffer network. The red crock clip and screened cable supply the 100Hz signal. All screening case lids must be fitted while measuring distortion.



automatic winding machines needed to produce capacitors in volume. The major German capacitor makers were leading these developments. Wima with others, worked to develop intricate machines capable of automatically winding individual small capacitors. The Siemens company, now Epcos, sought a different solution, their so-called 'stacked' capacitor. Despite their name, stacked film capacitors are first wound onto a large diameter wheel, to make a 'mother' capacitor. When all possible

processing stages are complete, this 'mother' is sawn into short lengths, each a discrete capacitor element.<sup>5</sup> During my initial distortion measurements on metallised PET capacitors, I was curious as to whether these two processes would result in different distortion characteristics. Concentrating my measurements on known wound BC Components type 470 and known stacked Epcos capacitors, I did find differences. The stacked film capacitors usually exhibited an increased third harmonic, compared to this wound type. My

initial stocks were too small to be statistically valid, so more capacitors were purchased.

**Wound v Stacked metallised PET**

At this time I measured distortion using only a single pure 1kHz tone and no DC bias. With 4 volts dropped across the capacitor, my equipment noise floor was below -140dB. Loaded with a 0.5% metal film resistor, distortion measured 0.00005%. Similarly the best capacitors typically measured 0.00006%, with second harmonic better than -125dB, third and higher harmonics better than -130dB.

Measuring 25 type 470 capacitors I found three having more than ten times higher distortion. Even harmonics were little changed, but third harmonic increased to -100dB, fifth to -115dB. Measuring another 25 capacitors I found two with high distortion. I set a good/bad limit at -120dB, any harmonic exceeding this level being viewed as bad.

The next step was measuring 25 stacked capacitors and I found most measured as bad. Distortions varied from 0.00034% to 0.0018% and many displayed -90dB third harmonics.

Was this difference genuine or was my sample still not statistically significant? Measuring more capacitors, I found some also having increased second harmonic distortions. I had anticipated finding third harmonic variations but did not understand these second harmonic problems, PET of course has significant



Figure 4: With no bias, this exceptionally good 0.1µF 63 volt type 470 metallised PET capacitor from BC Components, with magnetic leadwires, measured just 0.00004% distortion. With 18 volts DC bias, the second harmonic increased 22dB from -133.3dB to -111.4dB (distortion increased six times.) Intermodulation products are just visible, either side of 2kHz.



**Figure 5: Distortion measurement of a typical MKS2, with no DC bias measured just 0.00007%. With 18 volts DC bias the second harmonic increased 31dB from -128.3dB to -96.4dB. Intermodulation products and other harmonic levels did not change.**

dielectric absorption, typically 0.5%.<sup>6</sup> Several capacitors, pre-selected as good and very bad distortion, were accurately measured for capacitance and  $\tan\delta$  at 1kHz using my precision bridge, initially unbiased then with 30 volts DC bias. The biggest capacitance change found was less than 0.01% and with  $\tan\delta$  values remaining constant regardless of bias voltage, seemed to rule out any dielectric absorption effects.

Somewhat puzzled, I decided to expand my distortion measurements, changing the measurement stimulus in small steps and varying one test parameter only at a time. I would also look for intermodulation using two test frequencies and explore the affects of change of DC bias voltage. I had no choice but start again, repeating almost 1000 single frequency distortion measurements already saved to disk, both of film and electrolytic capacitors.

#### Revised measurements

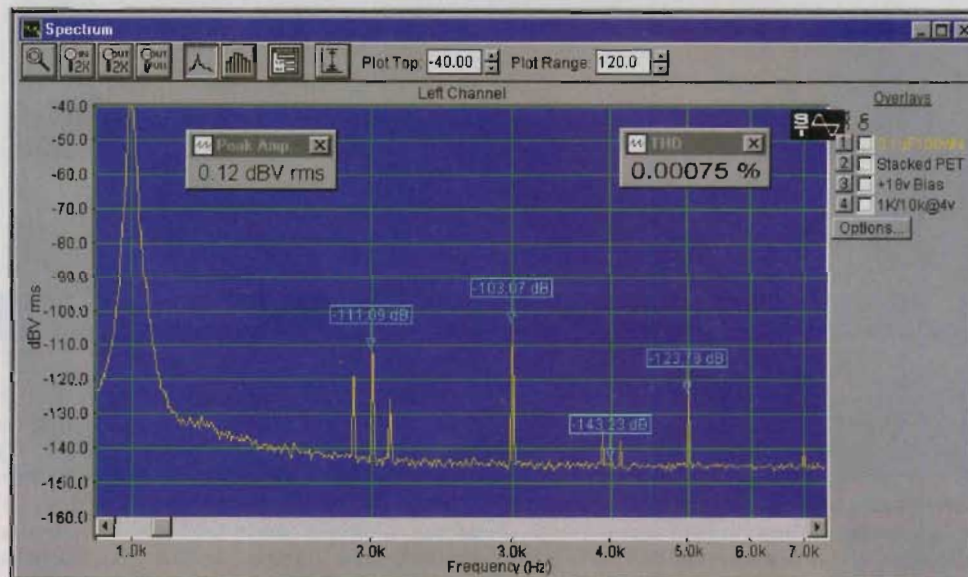
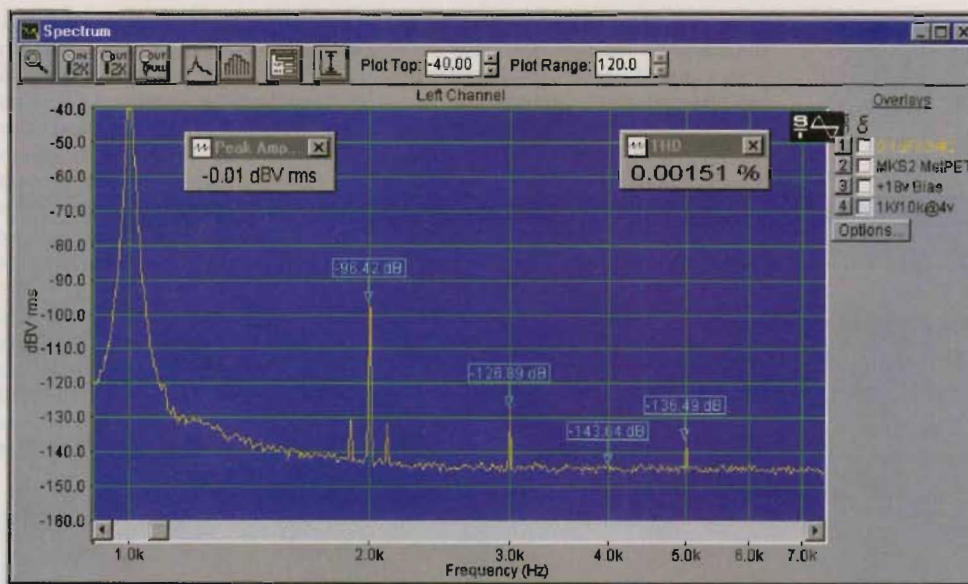
To prove my DC bias buffer contributed no distortion, I measured my near perfect  $1\mu\text{F}$  KP capacitor. Using 6 volt test signals at 100Hz and 1kHz and 50 volts DC bias, its distortion measured 0.00006%. This DC bias buffer was then used for all measurements. **Fig. 3.**

A 'good'  $0.1\mu\text{F}$  63v type 470 wound capacitor,  $\tan\delta$  0.00337, measured similar distortion when tested with no DC bias.

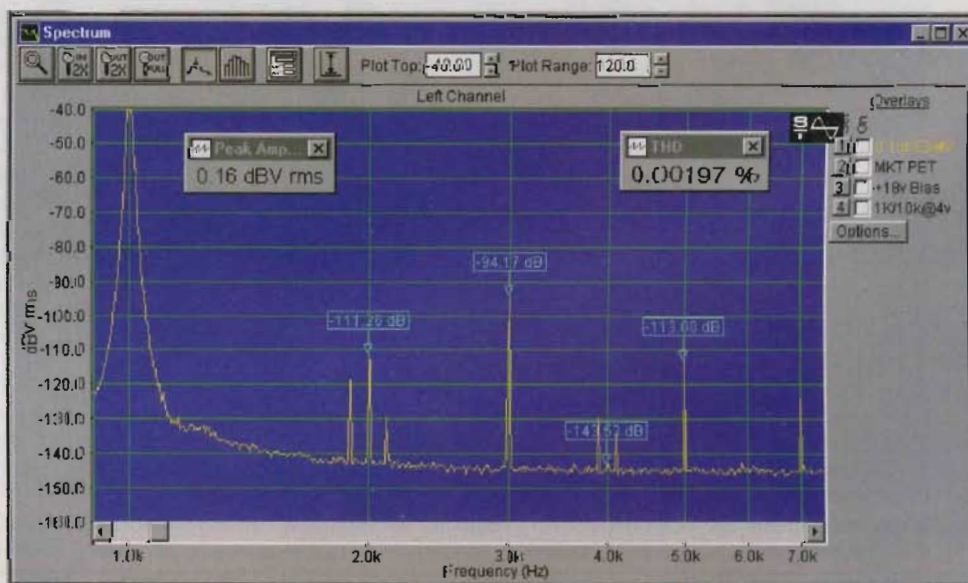
Intermodulation was just visible either side of the second harmonic. With 18 volt DC bias, second harmonic increased by 22dB and distortion to 0.00027%. **Fig. 4.**

A batch of Wima MKS2 wound capacitors consistently show increased intermodulation products and third and fifth harmonics. Typical no bias distortions measured around 0.0001%. With 18 volt DC bias the

**Figure 7: A different maker's very much smaller, 63 volt stacked metallised PET capacitor with copper lead wires exhibits worse distortions than those shown in figure 6. Notice however a family likeness of distortion components, similar to figure 6 but quite different from figure 4.**



**Figure 6: A 0.1µF 100 volt stacked metallised PET, with magnetic leadwires, displays increased odd harmonics and intermodulation components. The second harmonic of this much larger capacitor made with thicker PET, increased less with DC bias, compared to figures 4 and 5.**





second harmonic increased by 32dB and distortion measured 0.00151%. With a  $\tan\delta$  of 0.00272, this capacitor was dismantled to confirm it was wound construction. Fig. 5

A much bigger, 100 volt rated, uncased stacked capacitor with  $\tan\delta$  0.00352, shows a very high third harmonic level and increased intermodulation products, typical of

the construction. Made using thicker dielectric, its second harmonic increased by 16dB when biased with 18 volts. Due to its third harmonic, high distortions were measured with and without bias. Fig. 6

Third and odd harmonics vary with AC test signal, but DC bias from 0 volts to 30 volts, has almost no affect. These enormous changes in second harmonic, tested with and without bias, clearly result from the DC bias, dielectric thickness and dielectric absorption. (see box Dielectric Absorption.)

Uncertain of their construction, I ordered just ten MKT capacitors (Farnell 814-192) and all behaved similarly. Exceptionally high distortion with and without bias, dominated by the near -90dB third and -113dB fifth harmonics. With  $\tan\delta$  0.00371, this capacitor was dismantled to confirm it was stacked construction. Fig. 7

With such large variations in harmonic distortion, it seemed all small metallised PET capacitors should be distortion tested, to avoid building obviously 'bad' capacitors into the signal paths of audio equipment

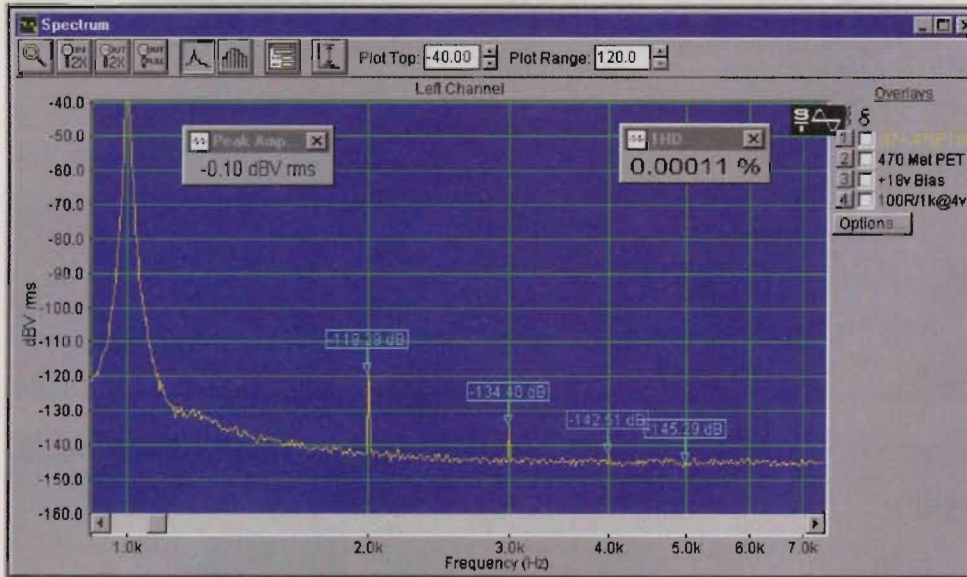


Figure 8: The first of two plots which explore the effect an increase in metallised PET film thickness might have on distortions. With no bias, distortion of this 100 volt capacitor measured 0.00006%, second harmonic -126.2dB. With DC bias, second harmonic increased by 7dB and distortion to 0.00011%

## Dielectric Absorption

Two major dielectric characteristics exist, polar and non-polar. By polar I am not referring to an electrolytic capacitor, but to the way the dielectric responds when subject to voltage stress. This stress relates to the voltage gradient across the dielectric and not just the applied voltage. In other words it is stress in volts per micron, which matters.

Non-polar dielectrics, for example vacuum and air, are little affected by voltage stress. Solid dielectrics which behave in a similar fashion are termed 'non-polar'. Most solid dielectrics and insulators however are affected to some extent, increasing roughly in line with their dielectric constant or 'k' value. This 'k' value is the increase in measured capacitance when the chosen dielectric is used to replace a vacuum or more usually, air.

When a dielectric is subject to voltage stress, electrons are attracted towards the positive electrode. The electron spin orbits become distorted creating mechanical stress and a so-called 'space charge' within the dielectric. This mechanical stress produces some heat rise in the dielectric and a power loss, called dielectric loss. Non-polar dielectrics exhibit very small power or dielectric losses. Polar dielectrics are

much more lossy. Having been charged to a voltage, it takes much longer for the electron spin orbits in a polar dielectric to return to their original uncharged state. Polar dielectrics produce easily measured 'dielectric absorption' effects.

Dielectric behaviour with voltage depends on the voltage gradient, in terms of volts/micron as well as on the characteristics of the dielectric. Its effects are more readily apparent with very thin dielectric. The lowest voltage, 50 and 63 volt rated metallised PET film capacitors are often made using 1 micron or thinner film. As will be seen in my next article, the dielectric used to make small low voltage electrolytics is perhaps one hundred times thinner. Consequently we should anticipate increased effects from dielectric absorption.

Foil and film capacitors cannot 'self heal' so must be made using relatively thick dielectric films. As a consequence we find that foil and film PET capacitors can provide low distortion, even when subject to DC bias voltages.

Dielectric absorption is usually measured by fully charging the capacitor for several minutes to a DC voltage, followed by a rapid discharge into a low value resistor for a few seconds. The capacitor is then left to rest for some time

after which any 'recovered' DC voltage is measured. The ratio of recovered voltage to charge voltage is called dielectric absorption.

So how might dielectric absorption affect the distortion produced by a capacitor? Many fanciful descriptions can be found, describing smearing, time delays and compression. My AC capacitance and distortion measurements, simply do not support these claims. The main characteristic I have found, which clearly relates to dielectric absorption, is the magnitude of the second harmonic. This does increase with applied AC or DC voltage stress and especially so with thin materials, having known higher dielectric absorption. For example, the PET (Polyethylene Terephthalate) and PEN (Polyethylene Naphthalate) dielectric films have almost identical characteristics except for dielectric absorption. Comparative distortion measurements with and without DC bias, made on metallised PEN and metallised PET capacitors, show that PEN capacitors do produce much larger second harmonics. The PEN material at 1.2%, has almost three times greater dielectric absorption than PET<sup>6</sup>



### The 1 $\mu$ F problem

To approach our idealised capacitor we need the small size provided by metallised PET, the low distortions found using Polypropylene and low cost. These qualities could be approached using metallised Polycarbonate, but Polycarbonate capacitors have become extremely expensive. With the production of Bayer Makrofol Polycarbonate film having ceased, metallised Polycarbonate capacitors may disappear.

A great many 0.1 $\mu$ F metallised PET capacitors had been measured, without finding clear reasons for their widely differing distortions. Would measurements at 1 $\mu$ F help?

I decided to measure the same make and style, rated at both 63 volt and 100 volt, to explore the D. Self comment that 63 volt capacitors exhibit ten times more distortion than

100 volt.<sup>7</sup> Provided the maximum capacitance possible at these voltages in both case sizes is obtained, dielectric absorption effects related in volts per micron to the differing film thickness used should be observed. It seemed probable that the 63 volt capacitor would exhibit increased second harmonic compared to the 100 volt version.

I choose to measure the 470 style capacitors, because 0.47 $\mu$ F at 100 volt and 1 $\mu$ F at 63 volt, were the maximum capacitances available in the case size. I soldered together several pairs of 0.47 $\mu$ F to produce near 1 $\mu$ F 100 volt capacitors.

Measured within a few minutes of each other, with no bias voltage, the 63 volt and 100 volt capacitors measured almost identically, with distortion at 0.00007% and 0.00006% respectively.

Re-measured with 18 volt DC bias, the third and higher harmonics were unchanged but second harmonic levels increased for both voltage ratings. Second harmonic for the 63 volt capacitors increased by +12.5dB, the 100 volt capacitors by +7dB, giving measured distortions of 0.00024% and 0.00011% respectively.

**Fig. 8** These figures equate well with the expected differences in film

### Technical Support

Interested readers are free to build a system for personal use or educational use in schools and colleges. Commercial users and replicators should first contact the author.

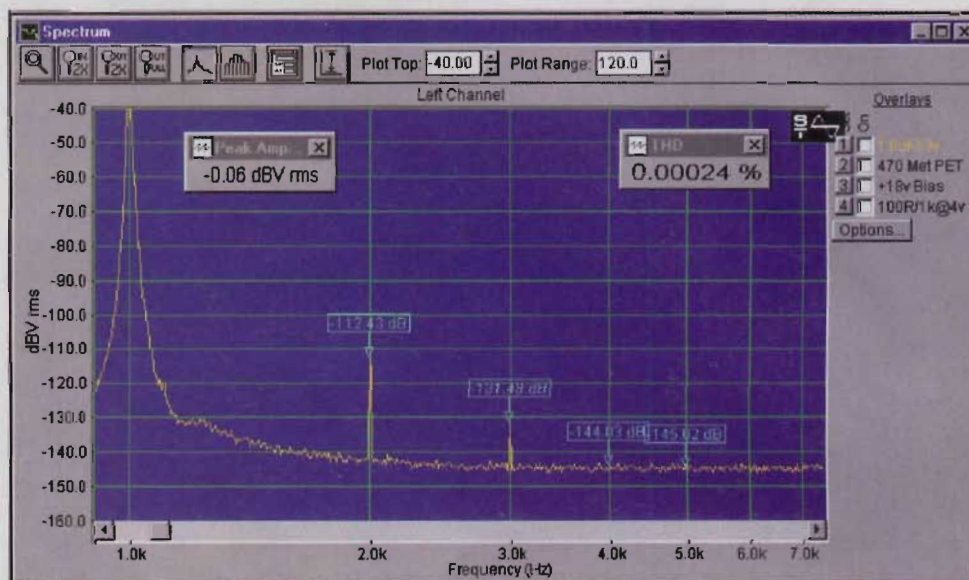
A professionally produced set of three FR4 printed circuit boards, with solder resist and legends, for the 1kHz signal generator, the output buffer amplifier/notch filter/pre-amplifier and the DC bias buffer network, comprising a 'with DC bias, single frequency, distortion test system'. Complete with component parts lists and assembly notes, the set of three boards costs £32.50.

Post/packing to UK address £2.50. Post/packing to EU address £3.50, rest of world £5.50.

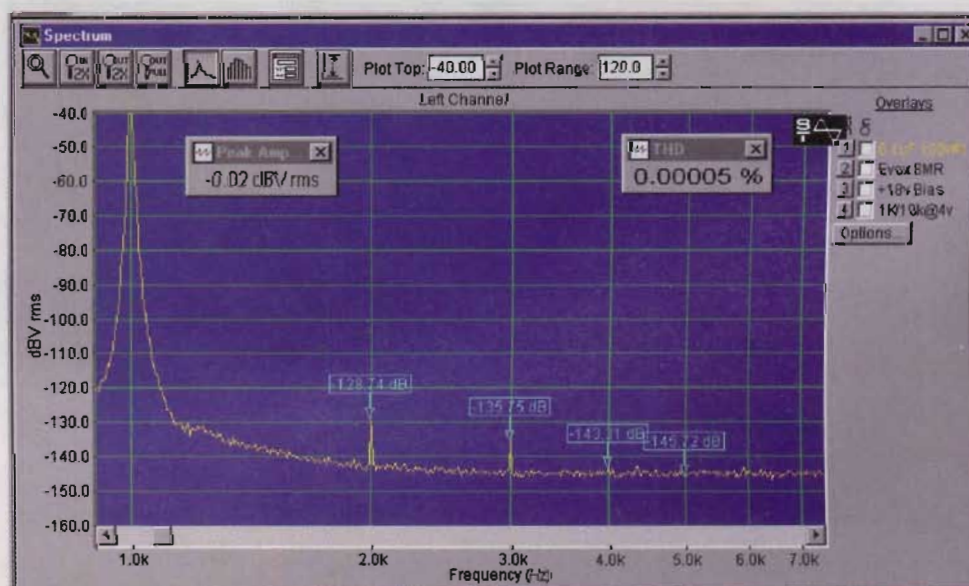
As a service to Non-UK readers, but only if ordered together with the above PCBs, I can now supply one four gang potentiometer with each set of boards, re-tinned and tested, for an additional £5.00 inclusive of postage.

Falcon Electronics (EW September) has these potentiometers in stock.

Postal Orders or Cheques, for pounds sterling only, to C. Bateman, 'Nimrod' New Road, ACLE, Norfolk NR13 3BD England.



**Figure 9:** Distortion of the 63 volt capacitor, same make comparison with figure 8. With no bias, distortion measured just 0.00007% with second harmonic at -124.9dB. With DC bias, second harmonic increased by 12.5dB. At 0.00024%, distortion is double that of the 100 volt capacitors.



**Figure 10:** This 0.1 $\mu$ F 100 volt Evox Rifa SMR capacitor, provides a superb low distortion performance with or without DC bias, even as high as 30 volts and no intermodulation products were seen.



thickness and confirmed the effect dielectric absorption has on second harmonic distortion. (see box Dielectric Absorption.) Some factor other than rated voltage, must account for Douglas's reported observation.

#### Fig. 9

Further measurements on  $1\mu\text{F}$  metallised PET capacitors, using 25 pieces of the wound type 470, and a similar quantity of stacked film capacitors, revealed nothing new. Distortion patterns established by the smaller capacitors were being repeated. I also had 10 pieces of wound capacitors type 370, dated 1995. These produced harmonic

levels with and without bias remarkably similar to those measured on the MKS2 types.

#### Possible mechanisms

These tests clearly illustrate how audible problems can exist using metallised PET capacitors in low distortion audio. I now sympathise with listeners who complain about amplifier sounds, when using metallised PET capacitors.

Lacking the facility to assemble test capacitors using known differences in materials and processes, I can only speculate as to possible reasons for the different third harmonic distortion

levels I found. These may result from differences in manufacture of the basic film or the vacuum deposition of the metallised electrodes, processes that vary from maker to maker.

It might even be as simple as the electrode metallisation thickness used. Perhaps thickness gives the wrong impression, this aluminium coating is so thin, like mirror sunglass lenses, it is quite transparent. Its thickness is measured in Ohms/square, typically some 2 to 4 Ohms.

One convenient explanation for these differences might be the use of copper versus magnetic leadwires. Not so, the lowest distortion, type 470 metallised PET capacitors tested use magnetic leads whilst the worst distortion stacked types used copper.

More likely are differences in the metal compositions and spray application methods used, to produce the 'schoop' end connections.<sup>5</sup> Aluminium metallised electrode has an electro-chemical potential of +1.66 volt, magnetic leads +0.44 volt, copper wires -0.337 volt. For the 'schoop' connection, a variety of other metals are used, having intermediate, mostly positive potentials. Possible 'Seebeck' effects should not be ignored. (see box Metallised film dielectrics.)

#### Intermodulation distortion

From many measurements using AC voltages from 0.5 to 6 volts, intermodulation products are produced in metallised PET capacitors according to the level of third harmonic the capacitor produces. For example a 'bad' capacitor exhibits intermodulation when subject to much less than 1 volt AC. A capacitor developing smaller third harmonic, shows no visible intermodulation until its AC voltage exceeds 3 volts. **Fig. 4**

The best metallised PET capacitors produced almost no distortion with no DC bias, but when used to block DC, second harmonic distortion increased rapidly with increasing DC bias voltage. Depending on circuit arrangements, many capacitors could produce audible distortions. Perhaps this should not surprise us. Audiophiles have claimed to be able to 'hear' PET capacitors for many years.

I believe that for  $0.1\mu\text{F}$  to  $1\mu\text{F}$  values, metallised PET capacitors should first be distortion tested. Because of their rapid increase in second harmonic with DC bias, they should not be used with significant DC bias, relative to their rated voltage, in high quality audio equipment. Having so far failed to find a physically small, economic,

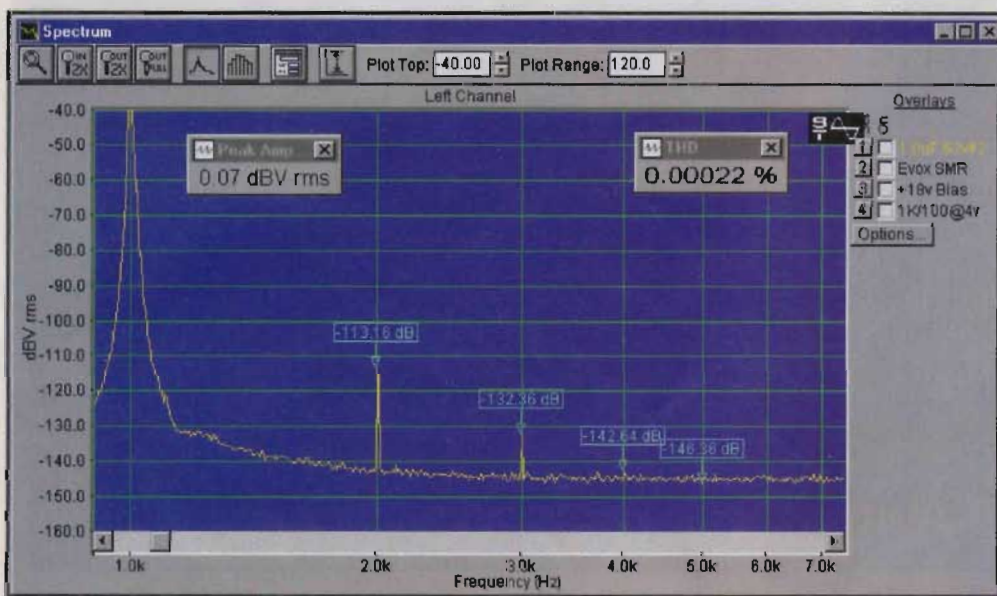


Figure 11: Little larger than their  $0.1\mu\text{F}$ , this  $1.0\mu\text{F}$  63 volt SMR capacitor from Evox Rifa behaves impeccably with or without DC bias up to 10 volts. With increased DC bias its second harmonic does increase but no intermodulation products were seen.

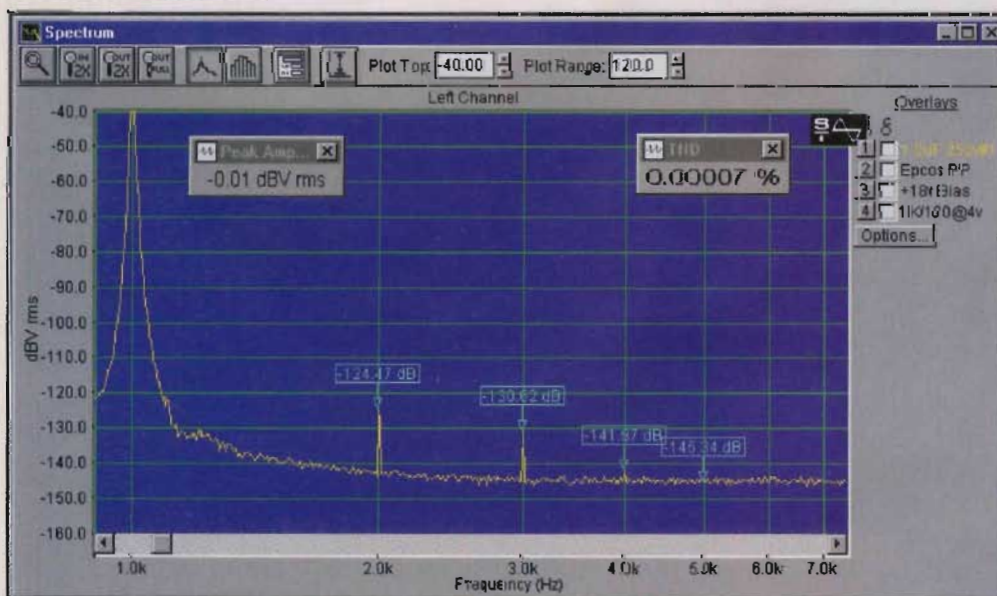


Figure 12: If you have room for a capacitor with 22mm lead spacing, this  $1.0\mu\text{F}$  250 volt Epcos with DC bias voltage, distorts less than most capacitors with no bias.



low distortion solution, is one possible?

### Polyphenylene Sulphide

A much better but little used, slightly more expensive dielectric has been available for many years.<sup>8</sup> It is available metallised down to 1.2 microns and with a 'k' of 3, it provides capacitors slightly larger than metallised PET.<sup>6</sup> It has many other benefits. Usable to 125°C, it provides a near flat temperature coefficient and  $\tan\delta$  slightly higher than metallised Polypropylene. It has a small dielectric absorption of 0.05%, better than Polycarbonate and ten times better than PET.

Like Polycarbonate, Polystyrene and COG ceramic, it provides superb long-term capacitance stability, changing only 0.3% maximum in 2 years. It seems Polyphenylene Sulphide (PPS) should provide acceptable size, low distortion capacitors.

I used 0.1 $\mu$ F 50 volt, 5mm centres Evox Rifa SMR metallised PPS capacitors, in my  $\tan\delta$  meter assemblies. Measurements of 25 pieces displayed extremely low distortion. This stock was purchased from RS, who has dropped the product from its catalogues, so I sought another stockist. The Farnell web site recently listed a small selection of Evox Rifa Polyphenylene Sulphide capacitors. Maximum stock value in 5mm lead spacing is 10nF, with up to 1 $\mu$ F at 63 volt in 10mm centres and at 100 volt in 15mm. The largest value, 3.3 $\mu$ F at 63 volt, has 15mm centres.

The 0.1 $\mu$ F 100 volt SMR produced superb results with and without DC bias voltage. **Fig. 10** The 1 $\mu$ F 63 volt produced superb results if biased to less than 10 volts but with increasing bias, second harmonic distortion increases. The larger 1 $\mu$ F 100 volt should be less sensitive. **Fig. 11** Both SMR types tested have small case size and 10mm lead spacing.

### Bigger the better?

Another new Farnell line is Polypropylene capacitors from Epcos (Siemens). The second harmonic of the 1 $\mu$ F 5% 250v B32653, with 22mm centres, changes little with DC bias up to 30 volts, distortion is then 0.00008%, a superb performance. **Fig. 12** The 0.1 $\mu$ F 5% 400v 15mm centres B32652, measured 0.00005% with 30 volts DC bias. **Fig. 13** Distortions from these 0.1 $\mu$ F and 1 $\mu$ F Epcos capacitors were not bettered by any similar sized capacitor I tested. With double the PCB footprint of the SMR types they may not fit your space. No

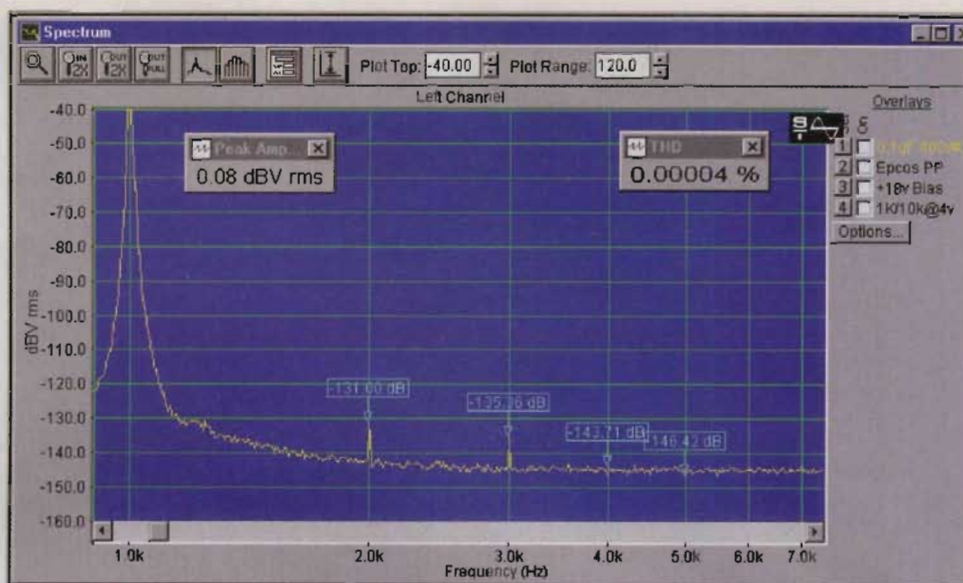


Figure 13: As good as Polystyrene? Distortions from this Epcos 15mm lead spacing 0.1 $\mu$ F 400 volt capacitor barely change even with 30 volts DC bias.

doubt these new lines will appear in the Farnell catalogue.

### Maintaining designed performance

Having measured several hundred metallised PET capacitors, I found many with extremely low distortions if measured without DC bias. I also found far too many showing very bad distortions, both DC biased and unbiased, yet metallised PET capacitors continue to be used in the signal paths of high quality audio amplifier designs.

To ensure the claimed performance of a published audio circuit can be repeated, the designer should declare the make, model and rated voltages of the capacitors. Simply stating ceramic, film etc. is totally unacceptable. These tests illustrate how a capacitor with an acceptable single frequency distortion test, can produce significant intermodulation on audio when presented with multiple frequencies.

Many years ago Ivor Brown presented the case that amplifier tests should comprise three test signals. This seems to have been completely ignored, at least in EW amplifier design articles.<sup>9</sup> Single tone 1kHz amplifier harmonic distortion tests ignore distortions caused by the rising impedance of capacitors at low frequencies. It is now clear that large amplitude bass notes and drum beats in music can result in peculiar intermodulation distortions, in an otherwise apparently good amplifier.

For my part I shall disregard any published audio designs which do not

report low frequency intermodulation distortion claims or low frequency harmonic distortion results, especially if the capacitors used are not properly chosen and adequately defined.

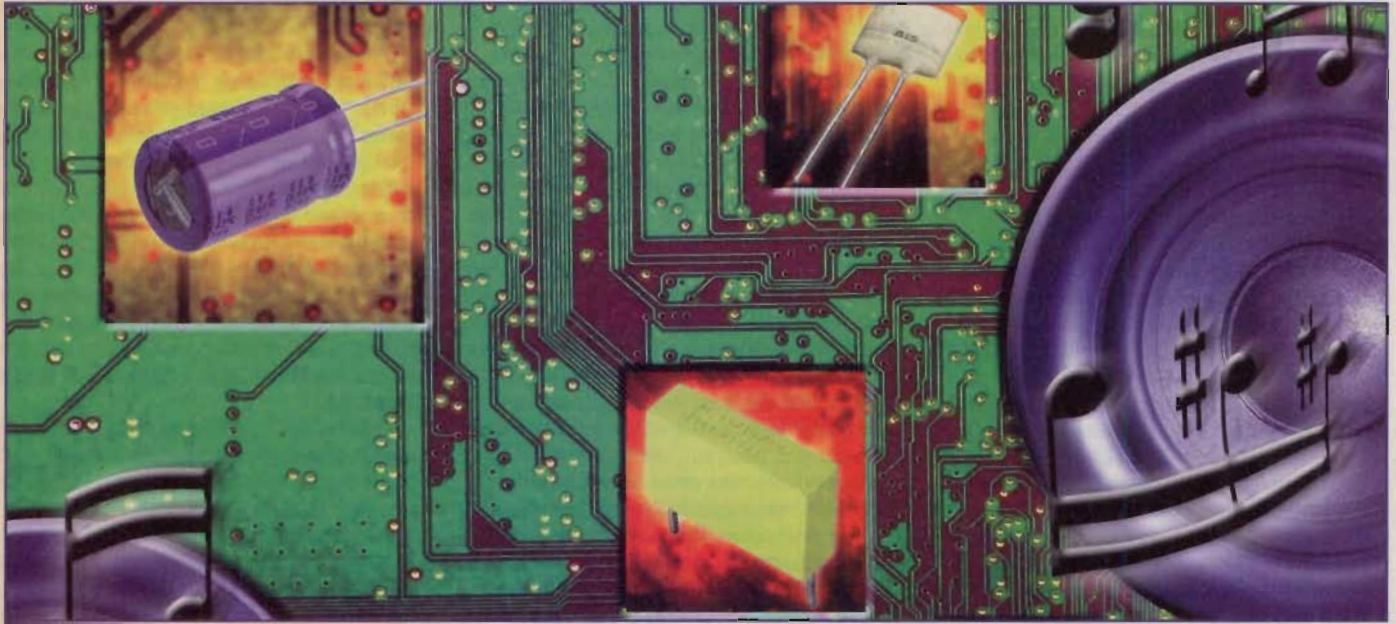
In my next article we introduce that most complex of capacitors, the electrolytic, then explore which produces the least distortion at 1 $\mu$ F, a metallised film or an electrolytic capacitor. ■

Some of the illustrations in last month's article were accidentally reduced too much, resulting in some of the text bordering on being illegible. Those diagrams are repeated over the next pages in larger form. Apologies.

### References.

1. Capacitor Sounds parts 1,2,3 C. Bateman EW July, September, October 2002
2. Picking Capacitors. W. Jung, R. Marsh Audio Magazine Feb/March 1980.
3. Barrier Layer Dielectrics. International Conference on Components. June 1961.
4. Decoupling Ceramic Disc 0.1mF 50 volt Maplin part BX03D
5. Understanding capacitors - Film. C. Bateman EW May 1998 p.391
6. Film Capacitors 2000. Evox Rifa AB., Kalmar, Sweden.
7. Precision Preamplifier '96. D. Self EW July/August 96 p.545
8. Capacitor Resistor Technology Symposium 1987 The Components Technology Institute.
9. Trial by three tones, I. Brown. EW Feb 91 page 131





# Capacitor sound 5

- 1 $\mu$ F choice - Electrolytic or Film?

**Many capacitors introduce distortions onto a pure sinewave test signal. In some instances distortion results from the unfavourable loading which the capacitor imposes onto its valve or semiconductor driver, though more often, the capacitor generates the distortion within itself.**

**Cyril Bateman continues his capacitive deliberations**

**F**or too long capacitor generated distortions have been the subject of much speculation and opinion. Capacitors are not categorised for distortion in manufacture, so a distorting capacitor would not be accepted as reject by its maker, but this can now be measured. Using my easily replicated test method, audio enthusiasts can select capacitors when upgrading their equipment and designers can select capacitors for each circuit requirement.

For 100nF capacitance we find the lowest distortions are generated by choosing either COG multilayer ceramic, metallised film Polyphenylene Sulphide (PPS) or double metallised film electrodes with Polypropylene (PP) film.<sup>1</sup>

At 1 $\mu$ F, COG ceramic types are not generally available, reducing our low distortion choice to the above two film types or a selected metallised Polyethylene Terephthalate (PET). To guarantee low distortion we found that metallised PET types should be distortion tested and used with no bias or with modest DC bias voltages. The PPS and PP capacitor types produce exceptionally low distortions but are larger and more expensive. **Fig. 1.**

To minimise costs at 1 $\mu$ F and above, many designers elect to use low cost polar aluminium electrolytic capacitors. We now explore this option.

## Electrolytic capacitors

At room temperature and 1kHz, a typical 1 $\mu$ F 63 volt polar electrolytic capacitor can sustain some 30mA AC current. By measuring its

distortion at 1kHz we obtain a direct comparison of polar electrolytic distortions with the film capacitors of my last article.

There are a lot of myths surrounding the aluminium electrolytic capacitor. As with other capacitor types, much has been written about the sound distortions they cause. However of all capacitor types, electrolytics are the most complex and the least well understood. Many myths, specific to electrolytics have emerged, based more on speculation than on fact.

- a) Aluminium electrolytic capacitor dielectric has extremely high 'k'.
- b) Electrolytic capacitor distortion is mostly third harmonic.
- c) For minimum distortion, electrolytic capacitors should be biased to half rated voltage.
- d) Back to back polarised capacitors, biased by the supply rail, minimise distortion.
- e) High ESR Electrolytics degrade sound quality, low ESR is always best.
- f) Electrolytics are highly inductive at audio frequencies.
- g) High voltage electrolytics sound the best.

A working knowledge of electrolytic construction combined with careful distortion measurements, leads to somewhat different conclusions.

## Polar Aluminium electrolytic construction

To begin to understand an electrolytic capacitor we must explore how it differs from other capacitor types including Tantalum.



Every traditional aluminium electrolytic capacitor actually comprises two polar capacitors in series, connected back to back.<sup>2</sup>

The dielectric for the wanted capacitance is a thin aluminium oxide coating that intimately covers the 'anode' foil. The metal core of this anode foil, acts as one capacitor electrode. The second electrode is provided by a conductive electrolyte surrounding the anode foil.

A 'cathode' foil is used to make electrical contact between this electrolyte and the lead-out wire. This cathode foil is covered by a much thinner, naturally occurring aluminium oxide, the dielectric for our second capacitor. Electrically similar to oxide produced using a 1 to 1.5 volt 'forming' voltage, capacitance of this cathode is many times that of the anode.

The effective surface area of the anode and cathode foils is much enlarged by mechanical and electro-chemical etching. Low voltage capacitor foil areas may be increased perhaps one hundred times larger than the foils superficial or visible area. In this process a myriad of minute tunnels are created in the aluminium foils, which become sponge like and porous.<sup>2</sup>

An extremely thin layer of dielectric, aluminium oxide with a 'k' of eight,<sup>3</sup> is electro-chemically 'formed' or grown on the surface of the anode foil. Depending on the desired end use, a general-purpose capacitor may be formed at 1.25 times, a long life capacitor to double its rated voltage.

The thickness of this dielectric oxide is self limiting, being controlled by the voltage used in the forming process. As thickness approaches 14 Angstrom for each forming volt applied, oxide growth slows down and almost ceases.<sup>2</sup>

Because aluminium oxide takes up more space than the aluminium which is converted in the 'forming' process, different etching methods are used according to the intended forming voltage. For the lowest voltage capacitors, the most minute tunnels are etched into both foils.

Formed to 50 volts, oxide growth would completely fill these minute tunnels. The etching process is adapted to produce somewhat larger tunnels, which can be formed - perhaps to 100 volts. For higher voltages, progressively larger tunnels must be etched.<sup>2</sup> Becromal (one supplier of capacitor foils) lists some fourteen different grades of etched anode and a bigger selection of cathode foils.

As capacitor rated voltage increases, less conductive electrolytes and thicker separator tissues must be used. To reduce element size and cost, thinner, lower gain cathode foils may be chosen.

These changes combine to produce a near optimum quality, low tan $\delta$ , low distorting capacitor when rated for 40 to 63 volt working, with notably poorer qualities above 100 volt and at the lowest voltage ratings.

### Assembly

The required length of anode and a slightly longer length of cathode foil are wound together, cathode foil out onto a small rotating spindle. To minimise mechanical damage to the extremely thin dielectric oxide coating, the foils are interwound together with soft insulating separators. Thin 'Kraft' or 'Rag' tissue paper the most common.

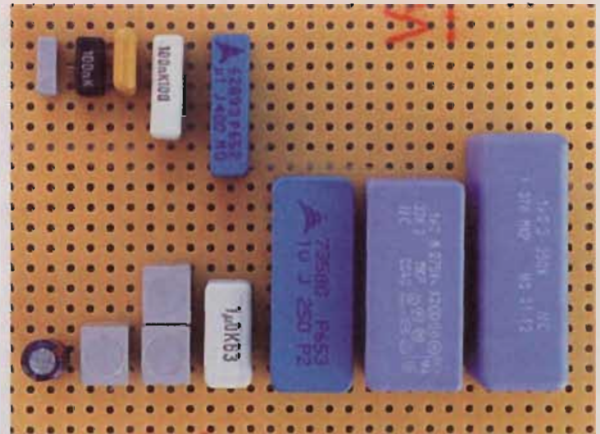
Aluminium has an electro-chemical potential of +1.66v. To avoid corrosion, no metal other than aluminium may be used inside the capacitor case. The external lead wires, copper at -0.337V or steel at +0.44V, must be excluded from all contact with electrolyte.

Prior to winding the element, thin aluminium connecting 'tabs' are mechanically and electrically connected to both foils. The most common method is 'eyeletting', when a shaped needle pierces both the connecting tab and its foil. Small 'ears' of tab material are turned over and well flattened down, effectively riveting both parts together. **Fig. 2.**

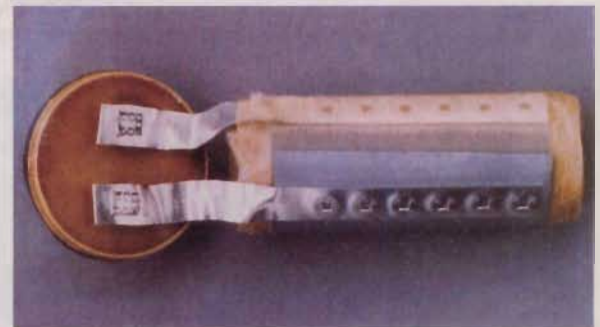
Cold pressure welds, seen in this photo connecting the aluminium 'tabs' to the outer tag rivets, provide the most reliable, low and linear resistance, connection of aluminium to aluminium. By applying pressure over small areas, metal is forced to flow between the two items, which become permanently welded together. This method is often used to replace 'eyeletting' in the best constructed capacitors. The completed winding is vacuum impregnated with electrolyte, which becomes absorbed into both foils and separator papers. Producing a low resistance connection between the anode and cathode foil capacitances.

### Bi-polar Aluminium electrolytic capacitor construction

A bi-polar electrolytic is made in exactly the same way as a polar capacitor, with one significant difference. In place of the cathode foil, we use a second anode foil. We still have two polar capacitances in series, back to back. Both now the



**Figure 1:** Bottom row left 1 $\mu$ F, the best electrolytic, the Bi-polar, was outperformed by the 470 type 63v metallised PET capacitor. The SMR capacitor is fourth and the B32653 fifth from left. Top row 0.1 $\mu$ F, the 50v and 100v SMR capacitors second and fourth, the B32652 fifth from left.



**Figure 2:** The 'eyeletting' type connections most often used to connect aluminium lead out tabs to the centres of both cathode and anode foils. For clarity the outermost anode and cathode foil turns have been removed. The cold pressure welds connecting these tabs to the tag rivets can be seen.

same value and working voltage. This bi-polar capacitor will measure half the capacitance of either anode foil - to make the required value, two anode foils, each double the desired capacitance, are used.

Aluminium electrolytic capacitor designers are accustomed to mixing and matching their available materials, to suit the capacitor's end application. So it should not surprise that some designs are semi bi-polar, i.e. they are made using a lower voltage deliberately 'formed' anode foil as cathode.

### Equivalent circuit

Using this constructional background, we can deduce an equivalent circuit for a polar aluminium electrolytic capacitor. **Fig. 3**

### Dielectric Oxide

Aluminium oxide has a 'k' of eight,<sup>3</sup> similar to that of COG ceramic or impregnated paper capacitors. It is rather higher than PET, which at 3.3, has the highest 'k' of commonly used films. A low value compared to the



'k' of several thousand, found in X7R and Z5U ceramics.<sup>4</sup>

While the impregnant used in paper capacitors is an insulator and acts as the dielectric, the electrolyte used in electrolytic capacitors is a conductor so cannot be a dielectric. This electrolyte is used to provide a low

resistance connection between the two capacitors. More significant than 'k' value is dielectric thickness. Large capacitance values are possible because the dielectric of a 50 volt aluminium electrolytic capacitor is some 100 times thinner than that used in a metallised film capacitor. Ref.2

As a result, electrolytic capacitors are sensitive to dielectric absorption effects.

The dielectric oxide film has a measurable voltage coefficient of capacitance. When DC biased, the measured capacitance of a 1µF 63 volt capacitor increased 0.15% at -0.5 volt. Initially decreasing 0.05% at +0.5 volt, capacitance then increased to +0.16% at +10 volt.

**Voltage effects**

We explore these voltage effects by measuring the distortion produced by a 1µF 63 volt polar electrolytic capacitor, subject to different AC test voltages. Commencing with 0.1 volt, capacitor distortion was measured at 0.1 volt increments to 1 volt. Initially we test with no bias, then with various DC bias voltages. Remember these voltages are those measured across the capacitor terminals and not the generator set voltage. Small test voltages reduce measurement dynamic range. Distortion of the test capacitor will be compared with those produced by a near perfect film capacitor, tested the same as reference. All tests use my DC bias buffer and two frequencies, 100Hz/1kHz to observe intermodulation.

Electrolytic capacitor behaviour varies with temperature. To minimise the affect of temperature changes, all reported tests were performed at constant room temperature. Unless otherwise stated, all voltages are RMS, measured using a DMM.

**Without DC bias**

Notably larger distortions were produced by this electrolytic than the film capacitor, even with a test signal as small as 0.1 volt, across the capacitor.

Figure 3: This simplified equivalent schematic illustrates how a polar electrolytic capacitor behaves. For clarity, components needed to account for dielectric absorption, are omitted.

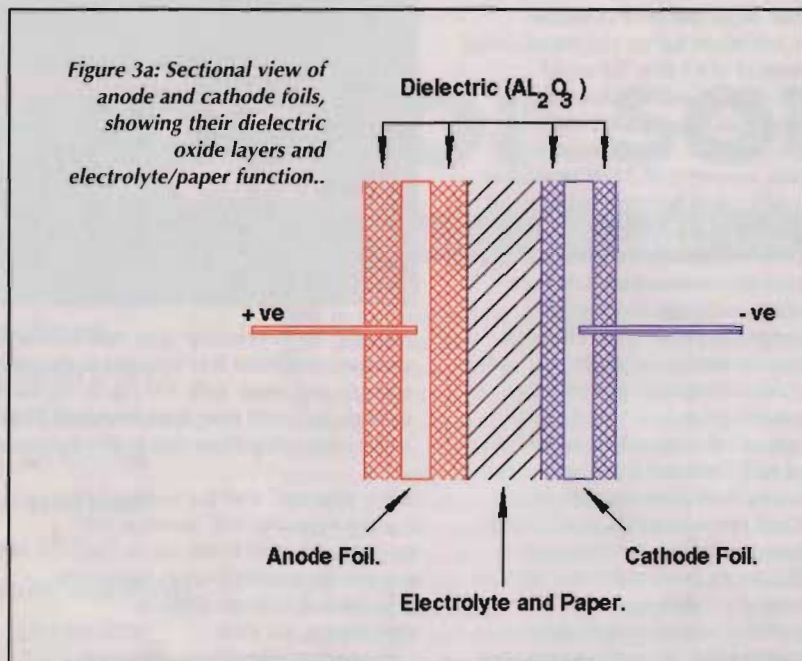
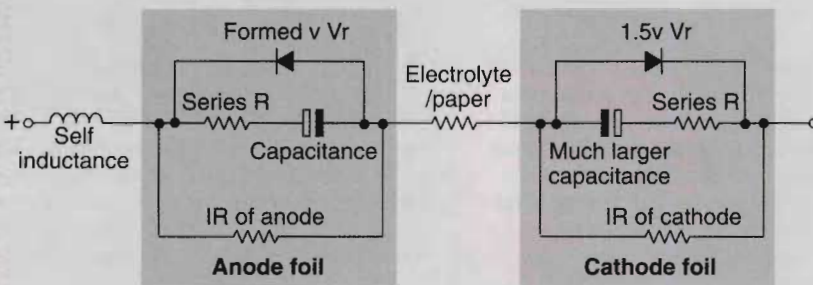


Figure 3a: Sectional view of anode and cathode foils, showing their dielectric oxide layers and electrolyte/paper function..

**Capacitance of an electrolytic**

The high capacitances available in an electrolytic are the result of the effective surface area of the etched and 'formed' anode foil combined with its exceptionally thin dielectric. This effective area is many times larger than the apparent or visible surface area. The extremely thin, electro-chemically 'formed' dielectric oxide film has a modest 'k' value of eight.<sup>3,6</sup>

$$\text{capacitance} = \frac{\text{electrode area} \times 'k' \times 0.0885}{\text{dielectric thickness, in pF/cm.}}$$

This increase in area or 'gain', is greatest for very low voltage rated capacitors, reducing with increasing voltage.

The cathode foil is covered by the oxide film which coats all aluminium surfaces once exposed to air. Some 20 Angstroms thick, it is equivalent to a 1.5 volt electro-chemically formed oxide. Much thinner than that 'formed' on the anode foil, this cathode foil oxide creates our second capacitor. It has a small

usable voltage and much larger capacitance than the anode foil.<sup>2</sup> Fig.3

This naturally occurring, extremely thin, low quality cathode foil oxide, has increased voltage coefficient than the anode foil. This cathode capacitor allows an aluminium electrolytic to operate on small AC voltages, without polarisation. Correctly polarised the 'formed' aluminium oxide dielectric on the anode foil is an excellent insulator. When reverse polarised it becomes a low resistance as though a diode has been connected in parallel with a good capacitor.

In similar fashion, the naturally occurring cathode oxide film behaves like a capacitor in parallel with a diode. This diode's polarity is in opposition with that of the anode. Because the cathode oxide is thinner, it produces a more leaky diode. The capacitor should never be reverse polarised. Any DC polarisation voltage must be correctly applied with the positive voltage to the capacitor's anode terminal.



Tested with a 0.3 volt signal, distortion of this typical 1µF 63 volt polar electrolytic capacitor, dominated by second harmonic, measured 0.00115% - almost three times greater than the reference capacitor. **Fig. 4.**

When the peak of the AC voltage applied across this unbiased polar capacitor exceeds some 0.5 volt, the cathode foil's voltage dependant effects increase. Tested at 0.4 volt RMS, both harmonics increase relative to the small change in test signal. Second harmonic voltage has almost doubled compared to the 0.3 volt test. Distortion is now four times greater than our reference capacitor. **Fig. 5.**

When the peak voltage across this capacitor exceeds some 0.8 volt, intermodulation distortions appear. Tested at 0.7 volt RMS, second and third harmonic levels have increased much faster than the test voltage. Distortion, dominated by the second harmonic, is now ten times greater than our reference capacitor. **Fig. 6.**

When subject to a 1 volt sinewave, the cathode capacitance varies even more and its diode may conduct on signal peaks. Much larger increases of distortion result, now 22.4 times greater than measured on the reference capacitor. **Fig. 7**

The above voltages apply to this test capacitor. With other combinations of anode voltage and cathode foil, these voltages will vary. With larger capacitance and lower voltage capacitors the same effects are observed, but frequently at smaller voltages.

Regardless of capacitance, working voltage or manufacturer, the second harmonic was the largest distortion component for every unbiased polar electrolytic capacitor measured.

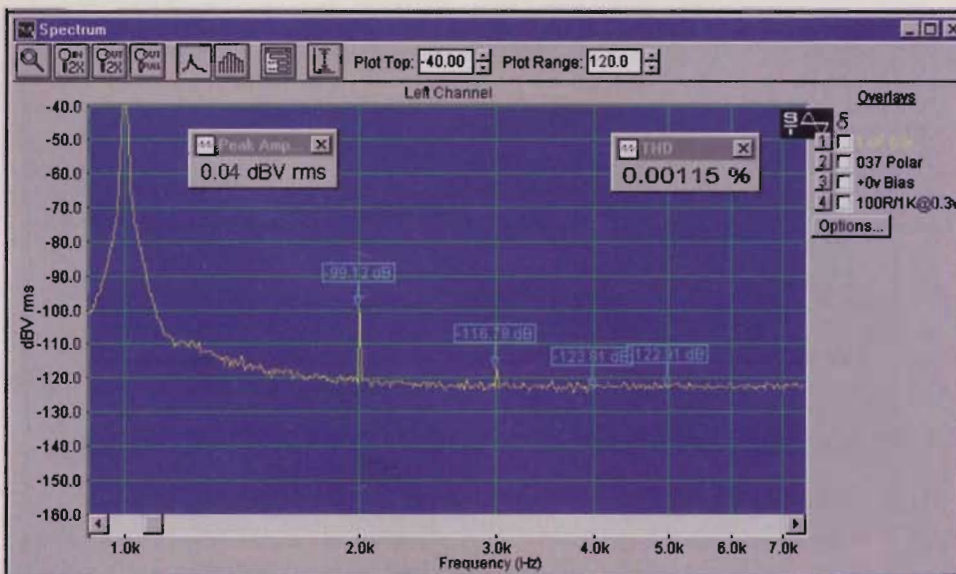
**Myth**

In the past various writers have stated that electrolytic distortion commences when a capacitor is subject to 1.4 volts peak, or 1 volt RMS sinewave. Doug Self once described this 1.4 volts as the voltage "which appears to be when depolarisation occurs in practise. Naturally distortion results as the capacitor dielectric film starts to come undone."<sup>5</sup>

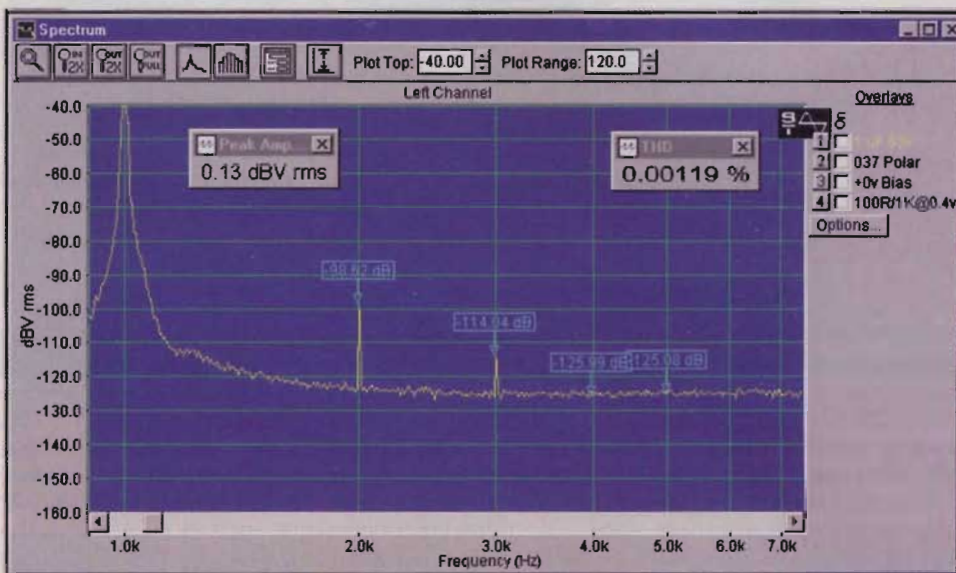
On both counts this is wrong. As we have seen, significant distortions occur at much lower voltages.

While the thin aluminium oxide film

*Figure 6: At 0.7 volt, with the third harmonic some -110dB below the test signal, intermodulation products can be seen either side of the second harmonic.*



*Figure 4: Distortions measured on our 1µF 63 volt polar capacitor, using a 0.3 volt test signal without DC bias. Note how the large second harmonic component dominates all others.*



*Figure 5: Both second and third harmonics have increased relative to the 0.4 volt test signal. The second much more than the third. Intermodulation components remain buried in the noise floor.*





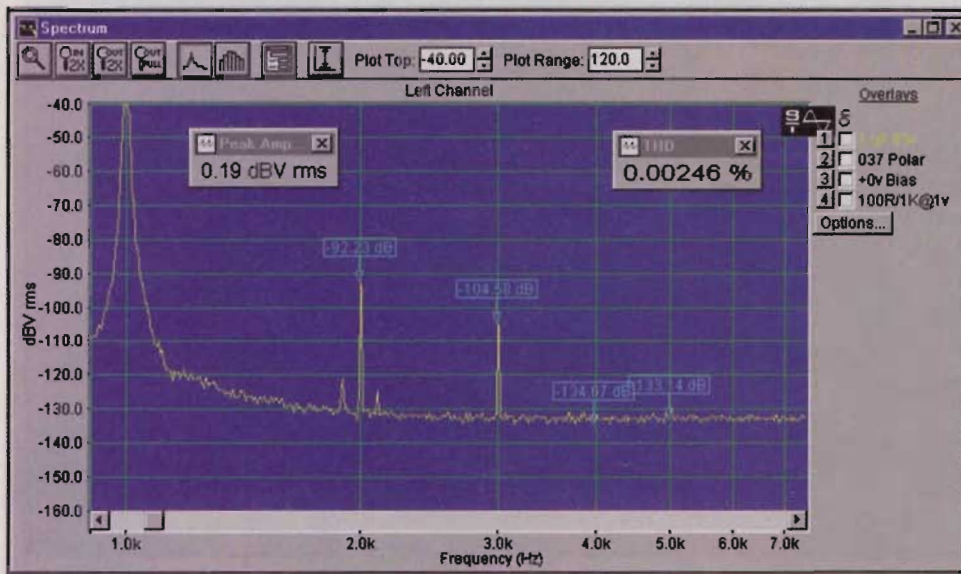


Figure 7: With a 1 volt test signal and no bias, the capacitor is producing 22.4 times more distortion than the film reference capacitor. Second and third harmonic components have increased out of all proportion to the test signal.

is easily mechanically damaged, like anodised aluminium, electro-chemically it is extremely robust. It requires substantial time and/or energy, to revert the aluminium oxide structure. Capacitor specifications permit short-term voltage reversals up to 1.5 volts, when the capacitor must

remain undamaged.

If severely abused by significant reverse voltage or excessive ripple current, a conventional aluminium electrolytic may explode. Not because the aluminium oxide film has deteriorated, but simply because these conditions result in large internal

currents. Hydrolysis releases gases from the electrolyte and internal pressure increases until the capacitor case breaks.

To help interpret the above results, I converted the 2nd and 3rd harmonic distortion levels into  $\mu\text{V}$ . Plotted against test voltage, both harmonic voltages clearly increase ever more rapidly with increase in test voltage. Fig. 8

### With DC bias

Looking once more at our equivalent circuit we see the anode and cathode foil leakage resistances with the electrolyte, create a DC potential divider chain. Application of a small positive DC bias with no AC signal, raises the electrolyte voltage above the negative terminal, see Fig. 3.

However subject to an AC test signal and DC bias, the anode and cathode capacitance values with their respective diodes, modify the electrolyte's potential. Tested with AC only, the electrolyte potential becomes slightly negative with respect to the negative terminal, resulting in an increase of second harmonic distortion. Subject to a small DC bias and an AC signal, the electrolyte potential increases. It can become zero or even slightly positive with respect to the negative terminal, reducing second harmonic distortion.

## Dielectric Absorption

In essence two major dielectric characteristics exist - polar and non-polar. By polar, I am not referring to an electrolytic capacitor, but the way a dielectric responds to voltage stress. This stress is the voltage gradient across the dielectric, and not simply the applied voltage. It is stress in volts per micron, which matters.

Vacuum and air, are little affected by voltage stress. Solid dielectrics which behave in a similar fashion are termed 'non-polar'. Most solid dielectrics and insulators are affected to some extent, increasing roughly in line with their dielectric constant or 'k' value. This 'k' value is the increase in capacitance when the dielectric is used to displace air.

When a dielectric is subject to voltage stress, electrons are attracted towards the positive electrode. The electron spin orbits become distorted creating stress and a so-called 'space charge' within the dielectric. This stress produces a heat rise in the dielectric, resulting in dielectric loss.

Non-polar dielectrics exhibit small losses but polar dielectrics are much

more lossy. Having been charged to a voltage, it takes longer for the electron spin orbits in a polar dielectric to return to their original uncharged state. Thin polar dielectrics, such as aluminium oxide, produce large, easily measured 'dielectric absorption' effects.

Dielectric behaviour with voltage depends on the voltage gradient in volts/micron and the characteristics of the dielectric. Its effects are more readily apparent at low voltages with thin dielectric. The dielectric used in low voltage electrolytics is exceptionally thin. Consequently we find increased effects from dielectric absorption when measuring these types.

Dielectric absorption is measured by fully charging the capacitor for several minutes, followed by a rapid discharge into a low value resistor for a few seconds. The capacitor is then left to rest for some time after which any 'recovered' voltage is measured. The ratio of recovered voltage to charge voltage, is called dielectric absorption.

So how might dielectric absorption affect the distortion produced by a

capacitor? Many fanciful, even lurid descriptions can be found, describing smearing, time delays and signal compression. My capacitance and distortion measurements do not support these claims. The main difference I found which clearly does relate to dielectric absorption, is the magnitude of the second harmonic. This increases with applied voltage, especially so with electrolytic capacitors.

My measurements indicate it is the level of third and odd harmonics generated by the capacitor that determines intermodulation products. These harmonics are little affected by DC bias on the capacitor. No doubt intermodulation distortions would contribute to a muddled or smeared background sound.

Third harmonic distortion depends on the peak voltage across the capacitor. For a given signal level, voltage across the capacitor will be greatest at the lowest frequencies. A low frequency, large signal peak, can trigger intermodulation distortions, which then affects higher frequencies.



These changes in electrolyte potential are easily confirmed by simulation using our equivalent circuit. This positive shift has a beneficial reduction on the AC signal non-linearity produced by the capacitor, measurable as a substantial reduction in second harmonic distortion. With optimum DC bias, the second harmonic may become smaller in amplitude than the third harmonic. Tested at 1 volt with 6 volt DC bias, distortion was reduced from 22.4 to 6.5 times greater than the reference capacitor. Fig. 9

**Myth disproved**

Only when a polar electrolytic capacitor is biased near its optimum voltage does second harmonic reduce, third harmonic may then dominate. Optimum bias varies with the applied

**Technical Support**

Interested readers are free to build a system for personal use or educational use in schools and colleges. Commercial users and replicators should first contact the author.

A professionally produced set of three FR4 printed circuit boards, with solder resist and legends, for the 1kHz signal generator, the output buffer amplifier/notch filter/pre-amplifier and the DC bias buffer network, comprising a 'with DC bias, single frequency, distortion test system'. Complete with component parts lists and assembly notes, the set of three boards costs £32.50.

Post/packing to UK address £2.50. Post/packing to EU address £3.50, rest of world £5.50.

As a service to Non-UK readers, but only if ordered together with the above PCB's, I can now supply one four gang potentiometer with each set of boards, re-tinned and tested, for an additional £5.00 inclusive of postage.

Falcon Electronics (EW September) has these potentiometers in stock.

Postal Orders or Cheques, for pounds sterling only, to C. Bateman. 'Nimrod' New Road, ACLE, Norfolk, NR13 3BD, England.

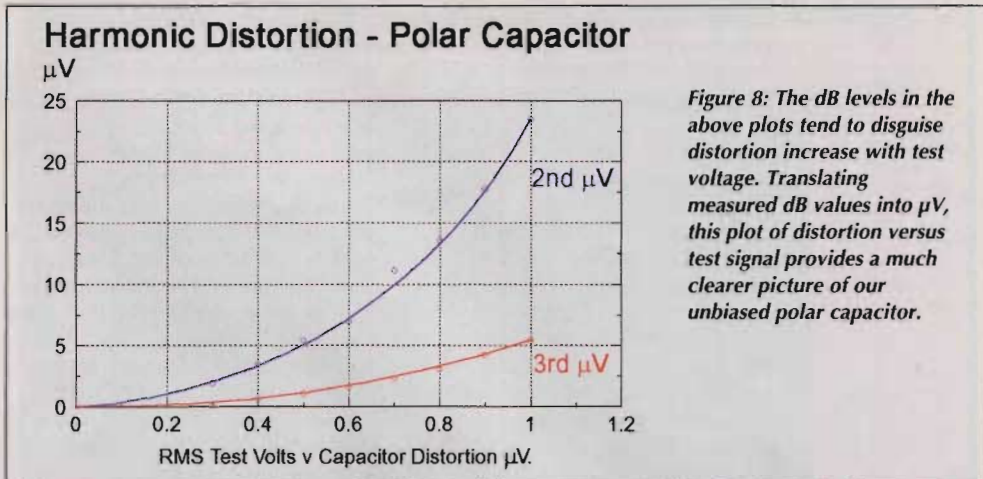


Figure 8: The dB levels in the above plots tend to disguise distortion increase with test voltage. Translating measured dB values into  $\mu\text{V}$ , this plot of distortion versus test signal provides a much clearer picture of our unbiased polar capacitor.

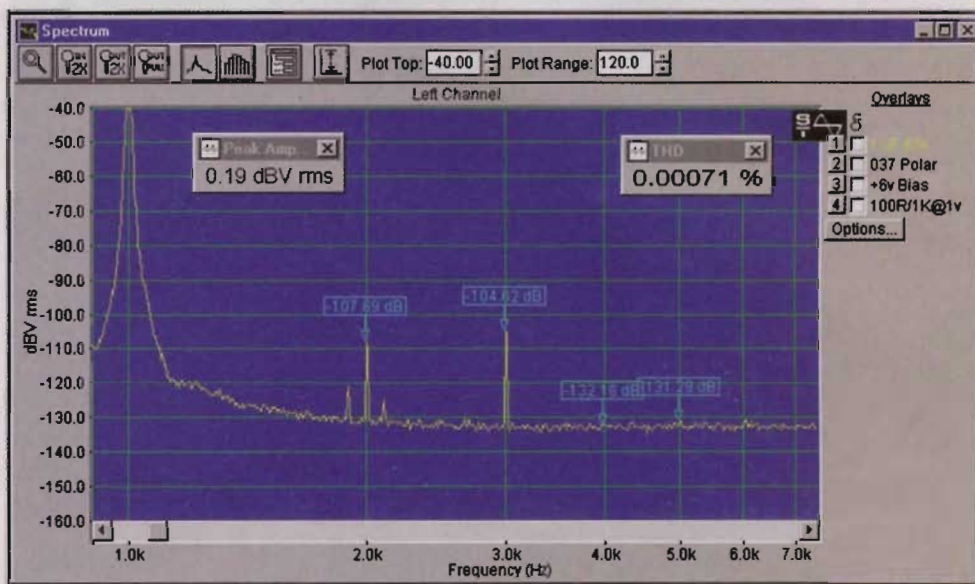


Figure 9: Measured as for figure 7 but using a 6 volt DC bias. Notice how the third harmonic and the intermodulation products remain constant despite the dramatic reduction in second harmonic level with this DC bias.

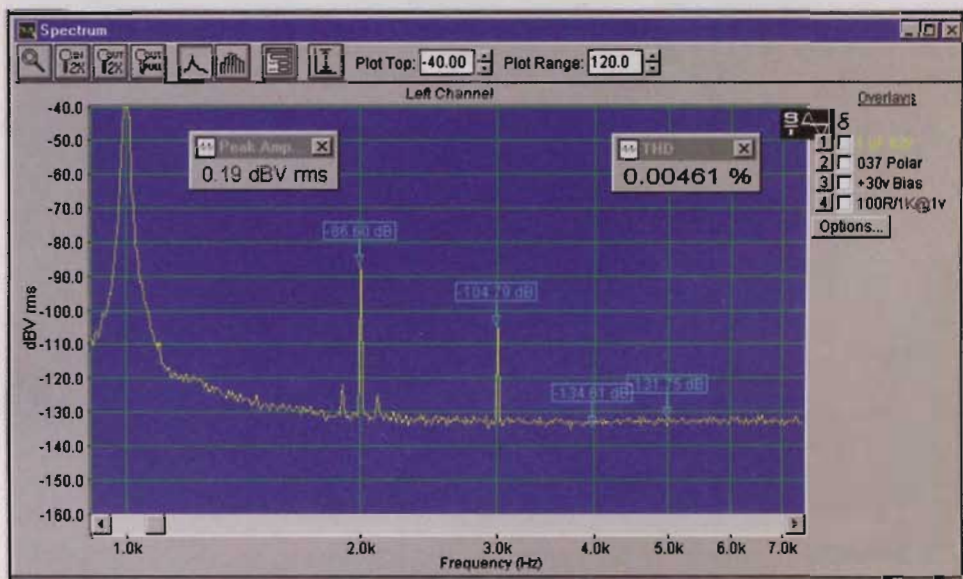


Figure 10: Measured as for figure 7 but with 30 volt DC bias. The capacitor is polarised to one half its rated voltage, the 'myth' value. Second harmonic has increased dramatically and distortion doubled compared to no bias figure 7. Intermodulation products and third harmonic are unchanged, from no bias to 30 volt.



AC signal, capacitor construction and even from capacitor to capacitor within a batch. From my tests, it ranged from less than 1 volt to some 12 volt.

With further increase of DC bias voltage, the effects of dielectric absorption outweigh this improvement. Second harmonic distortion increases rapidly with bias voltage. I re-measured this electrolytic and the reference capacitor at 1 volt AC with 30 volt DC bias, its 'mythical' optimum. Distortions dramatically increased, now almost 42 times greater than the reference capacitor. Fig. 10.

These changes in second harmonic amplitude, tested with and without DC bias, clearly result from the AC and DC voltages applied, dielectric absorption and dielectric thickness/formation voltage.

Non-linear effects in the interconnections, the oxide dielectric and the electrolyte/paper combination contribute third harmonic distortion. Third harmonic distortion increases with the applied AC signal. It does not change with DC bias voltage, remaining almost constant from zero to 30 volt DC bias. Figs. 7, 9, 10.

With increasing AC signal, when third harmonic distortion exceeds

some 0.0003% of the test signal, intermodulation distortions become visible above the measurement noise floor. Any increase in AC signal results in much increased intermodulation and harmonic distortions.

Typically the maximum signal voltage to avoid intermodulation distortion with this 1µF polar capacitor is around 0.5 to 0.6 volt. However, even at these voltages it still produces substantial harmonic distortion. Figs. 5 and 6.

### Bi-polar capacitor voltage effects

This construction provides two near identical anode foil capacitances, each subject to half the applied AC signal. Having no low quality cathode foil capacitance, it is freed from its non-linear effects so produces negligible distortion when unbiased. Distortion at 0.00017% is ten times smaller than the single polar electrolytic and just 50% greater than our reference capacitor. Fig. 11.

A DC bias voltage unbalances a bi-polar capacitor, resulting in increased second harmonic distortion. With 6 volt DC bias, second harmonic increased to -107.5dB and distortion measured 0.00044%. Little more than half the polar capacitor's distortion with this bias.

Subjected to 30 volt DC bias and a 1 volt test signal, second harmonic increased to -93dB. Third and higher harmonics are unchanged. Distortion at 0.00225% is less than half that of the 1µF polar capacitor and remains free from visible intermodulation.

### Two Polar capacitors back to back

Using two polar capacitors each of 2.2µF, connected in series and back to back, produces a chain of four capacitors, with a nominal 1µF capacitance.

With no bias voltage, each polar capacitor sees half the AC voltage. Second harmonic is much reduced and distortion measured 0.00034%. While substantially less than for the polar electrolytic, distortion is double that measured on the Bi-polar capacitor. Fig. 12.

With 6 volt DC bias, distortion of our 1µF polar capacitor reduced to 0.00071%, but more than 60% greater distortion than measured on the Bi-polar.

With 6 volt DC bias, second harmonic distortion of the back to back pair increased 20dB becoming dominant and distortion increased fivefold to 0.00169%. Fig. 13

At 1 volt AC, regardless of bias

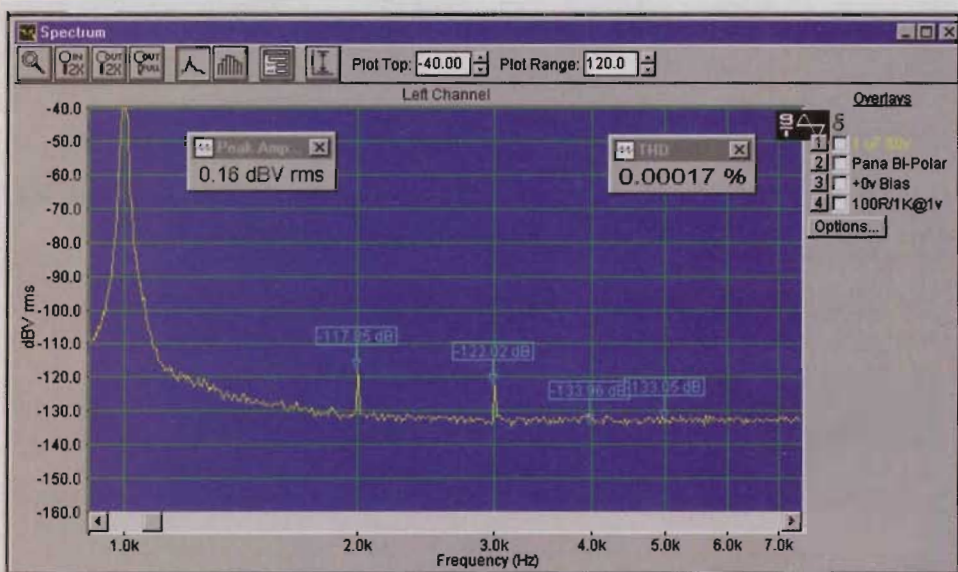


Figure 11: The bi-polar electrolytic of figure 1, measured unbiased as for figure 7. The bi-polar shows minuscule harmonic distortions and freedom from intermodulation products, compared to the polar electrolytic. Why do designers use polar electrolytic capacitors in the signal path of an amplifier?

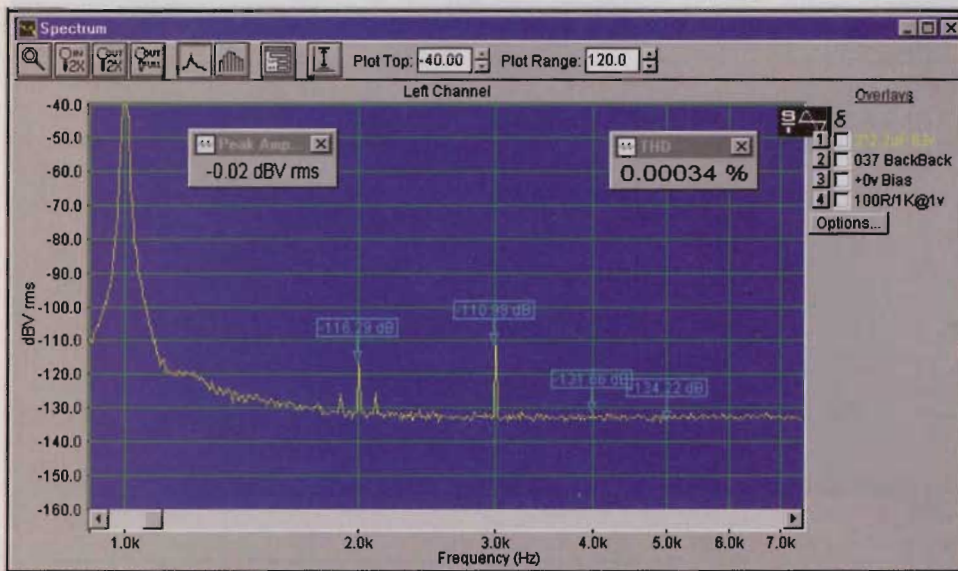


Figure 12: Two 2.2µF 63 volt polar capacitors connected back to back and measured unbiased as figure 11, produce less distortion than the polar capacitor. However with intermodulation products and double the distortion of the bi-polar capacitor, why use two polar capacitors, when one bi-polar is clearly better?



voltage, the single polar capacitor and the back to back pair both produced visible intermodulation.

With 30 volt DC bias, second harmonic distortion for both the single polar capacitor and the back to back pair measured -86dB. Both styles produced intermodulation and similar harmonic distortions, measuring 0.00461% and 0.00472% respectively. More than double that of the bi-polar. **Fig. 14.**

In every distortion test, the bi-polar capacitor produced much lower distortions than measured on similar value and voltage polar capacitors.

### Metallised film/electrolytic comparisons

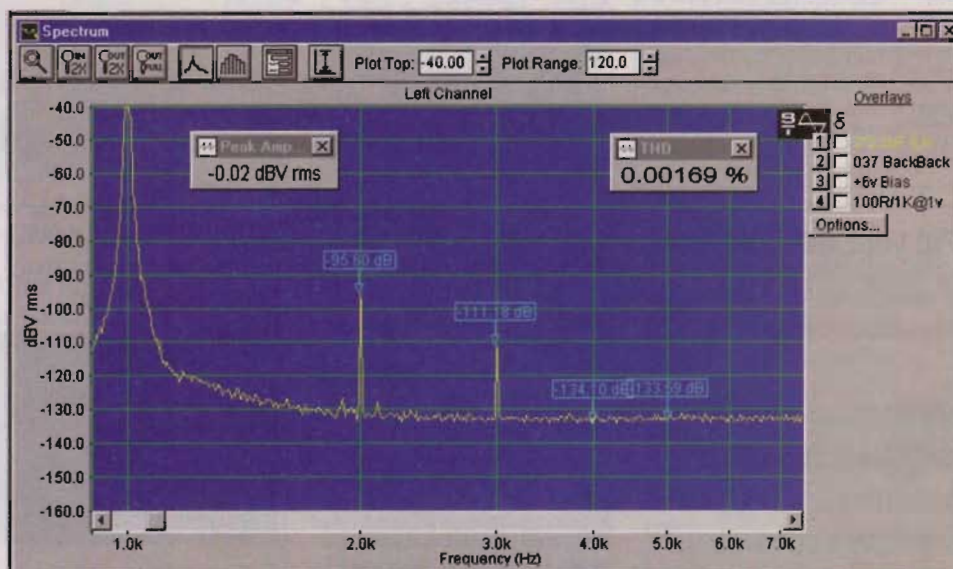
To measure distortions produced by the best film capacitors in my earlier articles, I needed to use a 4 volt AC test signal. I then found several 'bad' capacitors measuring higher than normal distortion.

This 4 volt test signal is much too large when testing electrolytic capacitors. Measured using 12 volt DC bias and a 2 volt test signal, all polar electrolytics produced very high levels of distortion.

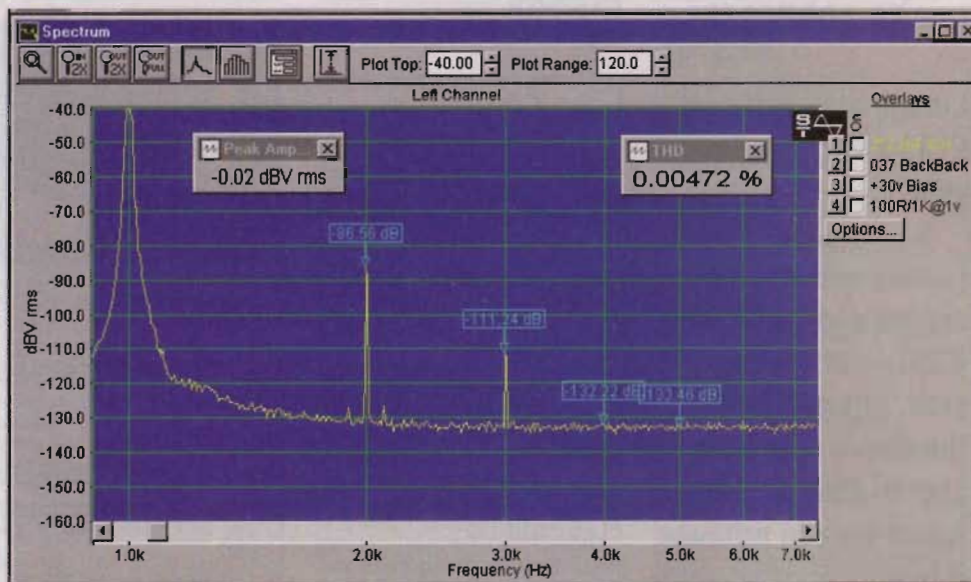
Reducing our test signal to 1 volt RMS to permit tests with and without DC bias voltage, which capacitor produces less distortion. A good electrolytic or a poor metallised PET capacitor? Regardless of bias, all polar electrolytic capacitors I measured at 1 volt generated significant levels of intermodulation distortion. The 1 $\mu$ F Bi-polar types were intermodulation free at 1 volt with no bias and to 30 volt DC bias. Measuring a 'known' 1 $\mu$ F metallised PET at 1 volt with no bias and to 30 volt DC bias, I found no visible intermodulation distortions. With 30 volt DC bias, second harmonic distortion was -100dB, distortion was 0.00089%.

The 1 $\mu$ F bi-polar electrolytic, tested at 1 volt and with 12 volt DC bias, measured almost identical distortions, which increased as bias increased. With 30 volt DC bias, second harmonic was -93dB and distortion measured 0.00225%, some 2.5 times worse than the PET. From these 1 volt tests the best 1 $\mu$ F electrolytic, the bi-polar type, was clearly beaten by the metallised PET.

Much better film capacitors were listed in my last article but at 1 $\mu$ F, a metallised PET capacitor provides the economic choice. For the lowest possible distortion, especially with increased signal drive or DC bias, the better quality film capacitor styles as shown in figure 1 and recommended in my last article, should be used. ■



**Figure 13:** Measured exactly as figure 9 with 6 volt DC bias, the back to back connection produces more distortion than our single polar capacitor. The bi-polar type is much better than both. With 6 volt DC bias it measured just 0.00044% distortion and no visible intermodulation products.



**Figure 14:** With DC bias increased to 30 volts, the back to back connected pair produces almost the same distortion and intermodulation products, as the single polar capacitor of Figure 10. The Bi-polar capacitor produced 0.00225%, half that of the polar or back to back capacitors and no visible intermodulation products. I repeat my questions.

### References.

1. Capacitor Sounds part 4 C. Bateman EW November 2002
2. Understanding capacitors - Aluminium and tantalum Electronics World June 1998 p.495. C. Bateman
3. Reference Data for Radio Engineers. Howard Sams & Co. Inc.
4. Understanding capacitors - Ceramic. Electronics World April 1998 p.324 C. Bateman
5. Letters page. D. Self. Electronics World April 1985 p.75
6. Understanding capacitors. C. Bateman Electronics World Dec 1997 p.998

### Additional Information

I am currently working to produce a CD ROM which will contain more capacitor details and figures showing many more distortion measurements than could be fitted into this series of articles, together with PDF files able to print the PCB artwork, assembly notes and parts lists.

I hope to have this CD ROM ready soon after my sixth and last article in this series is published, say mid December. Updated details in my next, the last article of this series. Expected cost £15 plus p/p.





# Capacitor sound 6

10-100 $\mu$ F capacitors and 100Hz measurements

**Many capacitors introduce distortions onto a pure sinewave test signal. In some instances distortion results from the unfavourable loading which the capacitor imposes onto its valve or semiconductor driver, though more often, the capacitor generates the distortion within itself.**

**Cyril Bateman concludes his capacitive deliberations**

**F**or the 1 $\mu$ F value, choosing a film capacitor or a bi-polar electrolytic generates the lowest distortions. In the tests, polar aluminium electrolytics produced considerably larger distortions, even with small AC signals.<sup>1</sup>

While high capacitance electrolytic capacitors can be obtained from distributors at low cost, cheap metallised film capacitors are restricted typically to 10 $\mu$ F at 100 volt and 22 $\mu$ F at 63 volt. In this final article, which completes last month's discussion on electrolytic capacitors, we explore whether a metallised film capacitor or an electrolytic is our economic, low distortion choice for capacitor values between 10 $\mu$ F and 100 $\mu$ F.

## Test frequency

To avoid overstressing large value electrolytic capacitors, we should reduce our test signal frequency towards 100Hz. But sufficiently above or below this frequency to discriminate between harmonics of the supply mains and the test capacitor. With minor changes in capacitance values, the PCB used for our 1kHz oscillator can provide an exceptionally low distortion 100Hz test signal.<sup>2</sup> In similar fashion the PCB used for our 1kHz notch filter and pre-

amplifier can also be used at this frequency.<sup>3</sup>

The AD811 low distortion buffer can output 40mA. At 100Hz using a 100 $\Omega$  series resistor, it can develop a 5 volt test signal across a 10 $\mu$ F capacitor. Using a 10 $\Omega$  resistor, 0.5 volts could be developed across a 100 $\mu$ F capacitor. These test voltages are more than sufficient to distortion test any electrolytic capacitor up to 100 $\mu$ F. However, when I designed the test instruments I decided to provide the ability to measure both values of film capacitors to 5 volts. To produce a larger test signal with 100 $\mu$ F capacitors, a more powerful buffer must be used. A low distortion circuit able to drive up to 400mA has been designed but needs a different PCB. Fig. 1

When testing large value capacitors, a four terminal test system is preferred and four BNC connectors are provided which accept either Hewlett Packard capacitor test jigs or four discrete cables and crocodile clips. Fig. 2

## Tantalum and aluminium electrolytic myths.

Some audio power amplifier designs have used small tantalum bead capacitors, with apparent success. Initial measurements of a



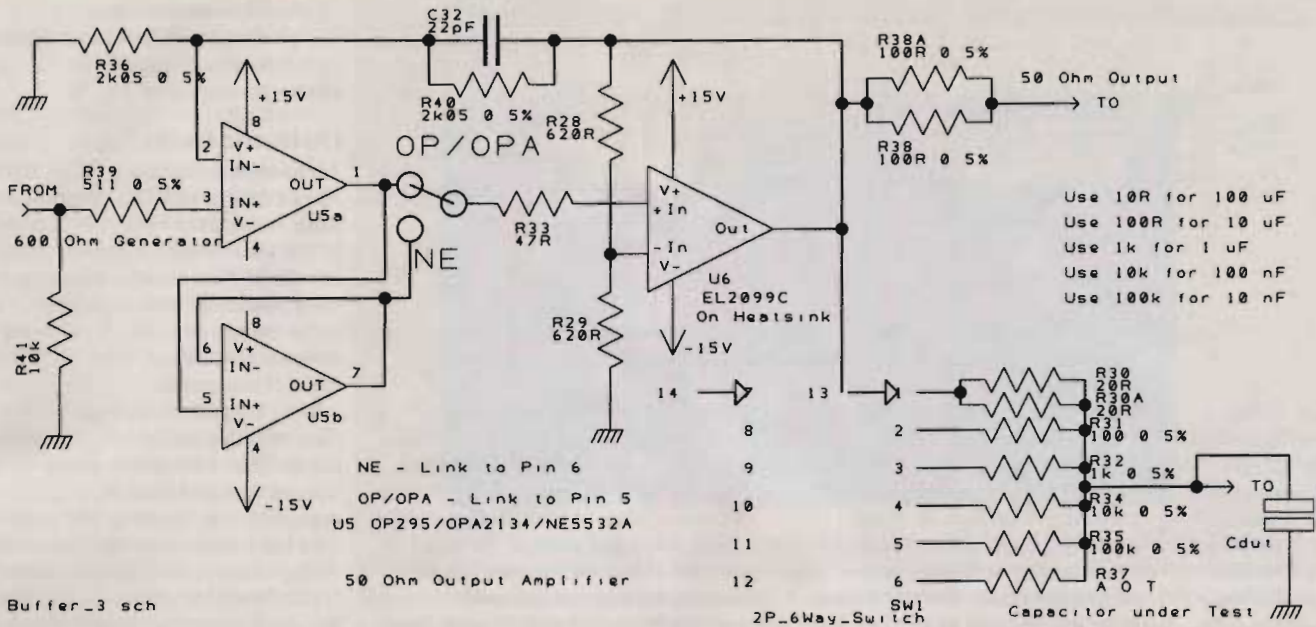


Figure 1: High power buffer provides low distortion, a gain of two and a 400mA output. It can develop more than five volts across a 100µF capacitor via a 10Ω current limiting resistor.

number of tantalum capacitors revealed large distortions. Measured at 0.3 volts with and without DC bias, my tantalum capacitor stocks produced at least ten times more distortion than found with low cost polar aluminium electrolytics. I decided to exclude tantalum bead capacitors from further tests. Fig.3

As with other capacitor types, much has previously been written about the sound distortions electrolytics produce. Most were discussed in my last article and the remainder will be in this.

- a) High ESR electrolytics degrade sound quality, low ESR is always best.
- b) Electrolytics are highly inductive at audio frequencies.
- c) Polar electrolytics should be biased to half rated voltage to reduce distortion.
- d) Electrolytic capacitor distortion is mostly third harmonic.

A working knowledge of electrolytic construction combined with careful measurements, leads to somewhat different conclusions.

**Inductance**

Radial lead electrolytics are assembled with their connecting tabs attached towards the centre of their anode and cathode foils. Wound together this produces a near non-inductive winding. The main contribution to the capacitor's self inductance then comes from the connecting lead wires and tabs and not the wound element.<sup>4</sup>

This is quickly proved. The largest

capacitor I measured for distortion, the Nitai 220µF 63 volt bi-polar, has a case size 25x16mm. I mounted one on a test jig and measured its self-resonant frequency. It was 250kHz, well above audible.<sup>5</sup>

**Polar & bi-polar electrolytics**

In my last article we saw that every polar aluminium electrolytic capacitor comprises two polar capacitors in series, back to back.<sup>1</sup> Wound with an anode and cathode foil, each foil with the electrolyte, comprises one capacitor. The cathode foil provides a larger

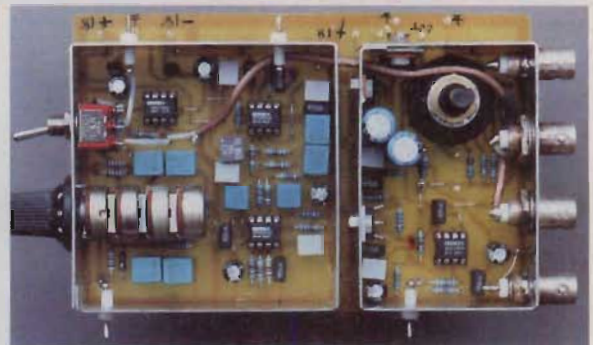


Figure 2: The higher power 100Hz test system. Four BNC connectors are arranged to accept Hewlett Packard test fixtures. The DC bias network inserts between the buffer amplifier and test fixture.

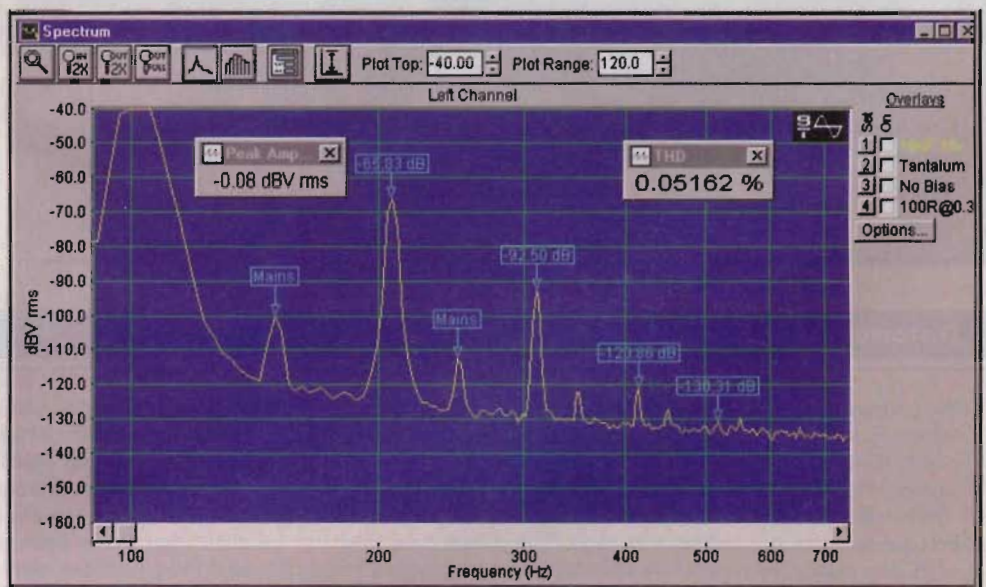


Figure 3: Distortion of this tantalum capacitor, ten times more than found with aluminium electrolytic capacitors, does reduce slightly with DC bias.



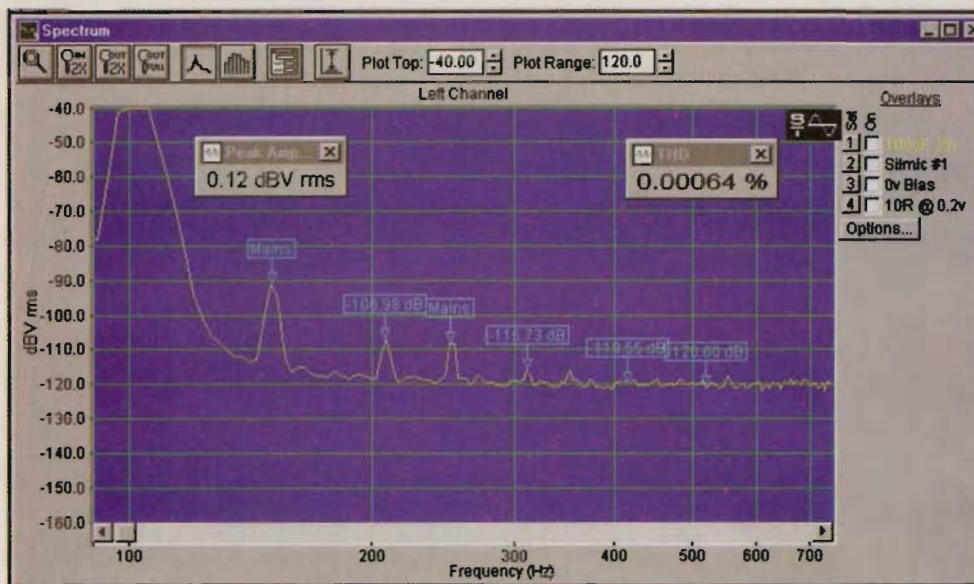


Figure 8: The 100µF 25 volt Silmic capacitor of Figure 5, tested at 0.2 volt. With no bias, second harmonic is 6dB smaller and distortion little more than half that of the more expensive Black Gate FK.

With and without bias, all electrolytic distortions increased more than the change of test signal. With no bias the Silmic performed best of the three electrolytics, outperforming the Black Gate FK by almost 6dB. Fig. 8.

With 18 volts DC bias, dielectric absorption effects increased the second harmonic of the Silmic by 21.7dB and it's distortion to 0.0054%. The Black Gate was less affected and its distortion increased to 0.0037%. The YXF distorted rather more, at 0.0063%. Third

harmonic distortions were visible above the noise floor, but not sufficient enough to produce measurable intermodulation distortion.

With a 0.3 volt test signal, the measurement noise floor improved to -123dB but the PET reference capacitor harmonics remain buried in noise. Second and third harmonics of the polar capacitors are now clearly visible, their distortions having increased much faster than the test signal level.

With a 0.3 volt test signal and no

bias, the Silmic, at 0.00098%, produced the least distortion of the three electrolytics. Its second harmonic measured -100.6dB, the Black Gate -98.5dB and the YXF -89.1dB. The best electrolytic produced more than three times the distortion of the PET assembly. Fig. 9.

With a 6 volt DC bias, the Silmic and Black Gate, with second harmonics around -90dB, produced similar 0.003% distortion. The YXF second harmonic was -87.3dB for 0.0043% distortion.

With 18 volt DC bias the Black Gate develops fifteen times more distortion than the PET assembly but distorts less than the other two electrolytics. Its second harmonic at -84.1dB was some 3dB better than the Silmic and 4dB better than the low cost YXF type. Distortions now measured 0.00637%, 0.00840% and 0.00951% respectively. Fig. 9B.

Third harmonics for all three electrolytics have reached the level for measurable intermodulation, which was confirmed by more tests, using 18Hz as the second frequency.

All three electrolytics produced significant distortions in this 0.3 volt test. Almost five times larger with no bias, at least fifteen times larger with bias, than my PET assembly. I consider distortions from these 100µF polar capacitors tested at 0.3 volt, exceed the sensible limit for use in the signal path of high quality audio.

Some writers advocate using a low

## 100 Hz test equipment

The oscillator and notch filter/preamplifier printed boards can be used at other frequencies by scaling the values of a few capacitors.<sup>2</sup>

### Oscillator board

For 100Hz, use 100nF 1% metallised Polypropylene for C1, C2, and C3. Bypass R16 by a wire link. To differentiate between test capacitor and mains frequency harmonics, replace R23, R24 and R25 with wire links.

### Twin-Tee notch filter/pre-amplifier board

For 100Hz, use 100nF 1% metallised Polypropylene for C41, C42, C43, C44, C47 and C48. Use 47nF 1% metallised Polypropylene for C45 and C46. Use 10nF 1% metallised Polypropylene for C49.

### Output Buffer.

At 100Hz, 10µF capacitors can be tested to 5 volts, using the AD811 output buffer amplifier described.<sup>3</sup> Adding a 10 Ohm current limiting resistor allows 100µF to be tested to 0.5 volts.

To fully test 100µF capacitors, a higher power buffer amplifier is needed. It should develop at least 5 volts signal across a 100µF capacitor via a 10Ω current limiting resistor.

I have designed a buffer amplifier and printed circuit board, able to drive up to 7 volts or 400mA, with extremely low distortion. An Elantec EL2099CT output amplifier is used with an input buffer. This can be an OP295, OPA2134 or an NE 5532A, by connecting one link. I used an OPA2134 in my prototype. Fig. 1

Larger decoupling capacitors are used with 1.5 Amp stabilisers. A Perancea 75 by 50mm PCB case serves as heat sink for the EL2099CT and the stabilisers.

Apart from these changes, the buffer amplifier schematic circuit and the current limiting resistors/switch follow the approach previously used for my 1kHz AD811 output buffer.

When testing 100µF, a four wire test method should be used. Four BNC connectors, two to output the test current and two to measure the capacitor distortions, are spaced at 22mm centres to fit Hewlett Packard capacitor test jigs. Alternatively, four discrete BNC cables and crocodile clips can be used.

To measure capacitors larger than 10µF with DC bias voltage, a DC blocking buffer circuit as already described but made with larger capacitors is essential.

Two 50µF 450 volt metallised Polypropylene motor run capacitors replaced the 11µF current carrying capacitors of my 1kHz design. Three 3.3µF MKP capacitors provide 10µF for the voltage measuring circuit. These components were mounted in a die-cast box and hardwired.

Four BNC connectors were mounted on opposite sides of this box, to mate with my 100Hz output buffer amplifier and the Hewlett Packard capacitor test jigs. Fig. 2

A selectable DC bias voltage was provided, by mounting 20 AA cells and a range switch, in a second die cast box. This was used with both DC blocking buffer designs.



1 volt. This capacitor provided the best 1 volt, no bias, results of the 100 $\mu$ F polar types in this article. Fig. 5.

### Lower voltage measurements

Accurate 100Hz distortion measurements using test signals smaller than 1 volt become quite difficult, for two main reasons.

- 1) Supply mains harmonics intrude everywhere and are difficult to reduce using a computer based system.
- 2) Inevitably, the smaller test signal reduces the dynamic range of our measurement, dramatically inflating indicated distortion.

For example, using a 0.1 volt test signal, my noise floor is around -112dB, hence a perfect capacitor producing no distortion at all will still register some 0.0005%. However, if we compare the measured harmonic levels of our electrolytic with those found for the identical measurement using a metallised film capacitor, we will see any increase in distortion caused by the electrolytic capacitor.

To distinguish between harmonics from the mains and the test capacitor, my test frequency was displaced a few Hz away from 100Hz. The Spectra software then ignores mains harmonics when calculating distortions. To assist visual identification, I used frequency markers to identify mains harmonics and amplitude markers to indicate the first four harmonics from the test capacitor.

At 100 $\mu$ F, a metallised Polypropylene capacitor is both large and costly. I used an assembly of 10 $\mu$ F Evox Rifa MMK metallised PET capacitors. This works well for small test voltages as a low distortion 'reference' capacitor. Fig. 6.

### Electrolytic distortion

As I've said before, despite some marketing claims, capacitors are not categorised for distortion, so a distorting capacitor would not be considered defective by its maker. It is the responsibility of the equipment designer to select the correct capacitor for each circuit.

During this investigation I measured many other polar electrolytics, rated from 10 to 100 volt and capacitance to 220 $\mu$ F, produced by major manufacturers. To illustrate this article, I decided to measure three quite different 100 $\mu$ F 25 volt polar electrolytic capacitors and my PET assembly. I tested the low cost Rubycon YXF, the larger more expensive Elna Silmic and the considerably more expensive Black Gate FK.

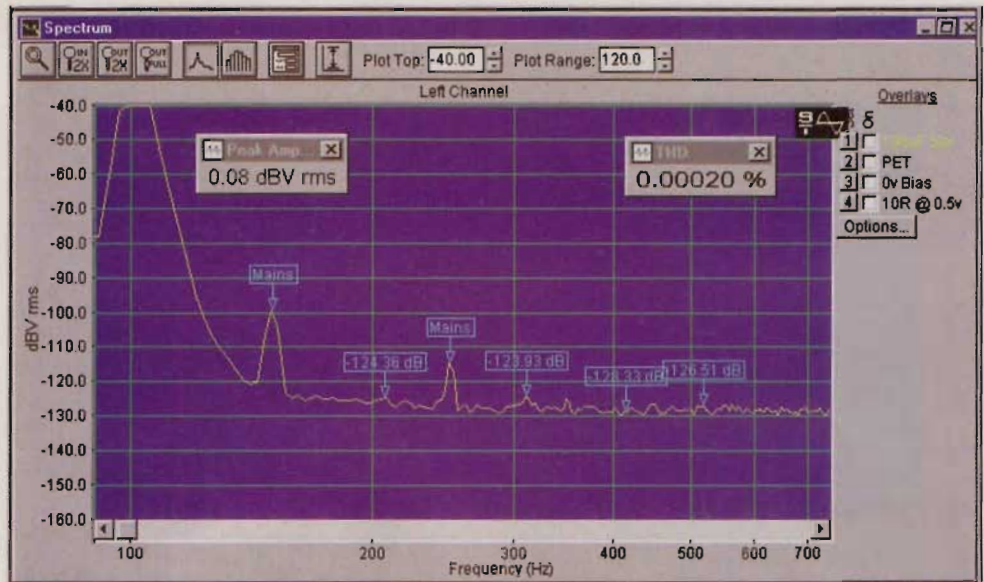


Figure 6: Distortion plot of an assembly of ten Evox Rifa 10 $\mu$ F 63 volt MMK metallised PET capacitors, tested at 0.5 volt. This 100 $\mu$ F assembly was used as the distortion reference for each test.

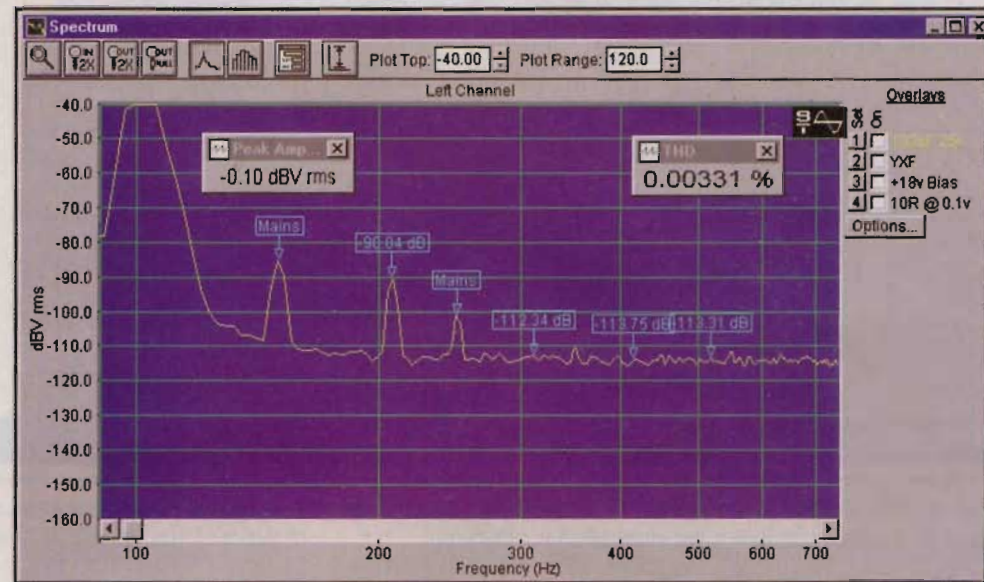


Figure 7: Distortion of a low cost, very small Rubycon YXF capacitor, tested at 0.1 volt with 18 volt DC bias, was less than 50% worse than the two larger, more expensive capacitors.

The Black Gate FK is a 21 $\times$ 10mm semi bi-polar, built using a low voltage anode as its cathode foil. The Silmic is 17 $\times$ 10mm and uses a special separator paper incorporating silk extracts. Both were purchased from Audiocom UK. The Rubycon YXF is a 12 $\times$ 6.5mm conventional, miniature, low ESR low cost capacitor purchased from Farnell.

Tests were performed using 0.1 volt AC to 0.5 volt AC in 0.1 volt steps, each using DC bias voltages of 0 volt, 6 volt, 12 volt and 18 volt, a total of 64 separate distortion measurements.

### 100 $\mu$ F 25 volt tests

With the 0.1 volt test signal, the measurement noise floor was reduced to -112dB. With no bias, distortions for the PET reference capacitor and the Black Gate FK were lost in noise. Second harmonic for the Silmic measured -106.1dB and the YXF measured -102.8dB. With 18 volt DC bias, second harmonic for all three electrolytic capacitors increased to between -90 and -94dB, distortions measured some three times greater than the PET assembly. Fig. 7

Using a 0.2 volt test signal, the noise floor improved to -118dB.



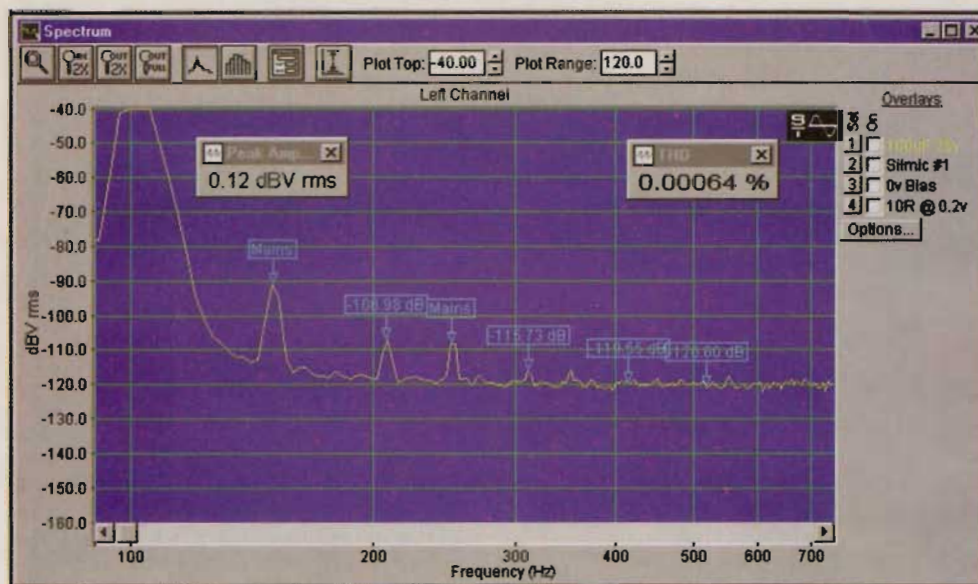


Figure 8: The 100µF 25 volt Silmic capacitor of Figure 5, tested at 0.2 volt. With no bias, second harmonic is 6dB smaller and distortion little more than half that of the more expensive Black Gate FK.

With and without bias, all electrolytic distortions increased more than the change of test signal. With no bias the Silmic performed best of the three electrolytics, outperforming the Black Gate FK by almost 6dB. Fig. 8.

With 18 volts DC bias, dielectric absorption effects increased the second harmonic of the Silmic by 21.7dB and it's distortion to 0.0054%. The Black Gate was less affected and its distortion increased to 0.0037%. The YXF distorted rather more, at 0.0063%. Third

harmonic distortions were visible above the noise floor, but not sufficient enough to produce measurable intermodulation distortion.

With a 0.3 volt test signal, the measurement noise floor improved to -123dB but the PET reference capacitor harmonics remain buried in noise. Second and third harmonics of the polar capacitors are now clearly visible, their distortions having increased much faster than the test signal level.

With a 0.3 volt test signal and no

bias, the Silmic, at 0.00098%, produced the least distortion of the three electrolytics. Its second harmonic measured -100.6dB, the Black Gate -98.5dB and the YXF -89.1dB. The best electrolytic produced more than three times the distortion of the PET assembly. Fig. 9.

With a 6 volt DC bias, the Silmic and Black Gate, with second harmonics around -90dB, produced similar 0.003% distortion. The YXF second harmonic was -87.3dB for 0.0043% distortion.

With 18 volt DC bias the Black Gate develops fifteen times more distortion than the PET assembly but distorts less than the other two electrolytics. Its second harmonic at -84.1dB was some 3dB better than the Silmic and 4dB better than the low cost YXF type. Distortions now measured 0.00637%, 0.00840% and 0.00951% respectively. Fig. 9B.

Third harmonics for all three electrolytics have reached the level for measurable intermodulation, which was confirmed by more tests, using 18Hz as the second frequency.

All three electrolytics produced significant distortions in this 0.3 volt test. Almost five times larger with no bias, at least fifteen times larger with bias, than my PET assembly. I consider distortions from these 100µF polar capacitors tested at 0.3 volt, exceed the sensible limit for use in the signal path of high quality audio.

Some writers advocate using a low

## 100 Hz test equipment

The oscillator and notch filter/preamplifier printed boards can be used at other frequencies by scaling the values of a few capacitors.<sup>2</sup>

### Oscillator board

For 100Hz, use 100nF 1% metallised Polypropylene for C1, C2, and C3. Bypass R16 by a wire link. To differentiate between test capacitor and mains frequency harmonics, replace R23, R24 and R25 with wire links.

### Twin-Tee notch filter/pre-amplifier board

For 100Hz, use 100nF 1% metallised Polypropylene for C41, C42, C43, C44, C47 and C48. Use 47nF 1% metallised Polypropylene for C45 and C46. Use 10nF 1% metallised Polypropylene for C49.

### Output Buffer.

At 100Hz, 10µF capacitors can be tested to 5 volts, using the AD811 output buffer amplifier described.<sup>3</sup> Adding a 10 Ohm current limiting resistor allows 100µF to be tested to 0.5 volts.

To fully test 100µF capacitors, a higher power buffer amplifier is needed. It should develop at least 5 volts signal across a 100µF capacitor via a 10Ω current limiting resistor.

I have designed a buffer amplifier and printed circuit board, able to drive up to 7 volts or 400mA, with extremely low distortion. An Elantec EL2099CT output amplifier is used with an input buffer. This can be an OP295, OPA2134 or an NE 5532A, by connecting one link. I used an OPA2134 in my prototype. Fig. 1

Larger decoupling capacitors are used with 1.5 Amp stabilisers. A Perancea 75 by 50mm PCB case serves as heat sink for the EL2099CT and the stabilisers.

Apart from these changes, the buffer amplifier schematic circuit and the current limiting resistors/switch follow the approach previously used for my 1kHz AD811 output buffer.

When testing 100µF, a four wire test method should be used. Four BNC connectors, two to output the test current and two to measure the capacitor distortions, are spaced at 22mm centres to fit Hewlett Packard capacitor test jigs. Alternatively, four discrete BNC cables and crocodile clips can be used.

To measure capacitors larger than 10µF with DC bias voltage, a DC blocking buffer circuit as already described but made with larger capacitors is essential.

Two 50µF 450 volt metallised Polypropylene motor run capacitors replaced the 11µF current carrying capacitors of my 1kHz design. Three 3.3µF MKP capacitors provide 10µF for the voltage measuring circuit. These components were mounted in a die-cast box and hardwired.

Four BNC connectors were mounted on opposite sides of this box, to mate with my 100Hz output buffer amplifier and the Hewlett Packard capacitor test jigs. Fig. 2

A selectable DC bias voltage was provided, by mounting 20 AA cells and a range switch, in a second die cast box. This was used with both DC blocking buffer designs.



distortion film capacitor in parallel with an electrolytic, to reduce distortion. Does it work?

### Using a film shunt

To find out, I made a few measurements on these capacitors using a 1 volt test signal, unbiased then with 18 volt DC bias. As a shunt I used my low distortion 1 $\mu$ F MKP and also a 10 $\mu$ F bank of three 3.3 $\mu$ F low distortion metallised PPS capacitors.

With 1 $\mu$ F shunt, second and third harmonics of the Silmic reduced by just 1dB. Using the 10 $\mu$ F, both harmonics reduced by a further 1dB. This small reduction is not worth the

additional PCB space and extra cost, because even with a 10 $\mu$ F shunt, distortions far exceed those of my metallised PET assembly.

Perhaps a higher voltage capacitor would measure better, or would its longer anode and cathode foils simply make matters worse?

### 100 $\mu$ F 50 volt tests

Examination of my earlier distortion plots suggested the only suitable 100 $\mu$ F electrolytic types I had which might measure lower distortion were the 22 $\times$ 12.5mm 50 volt Silmic and the 26 $\times$ 12.5mm 50 volt Panasonic S bi-polar, Farnell 218-698. With a 0.3 volt test signal and no bias, the 50

volt Silmic distorted more than the 25 volt version. Because of its much longer foils, the second harmonic increased 2dB, the third, 7dB and distortion measured 0.00134%.

### Fig. 10.

Due to the thicker dielectric used for the 50 volt capacitor, with 18 volt DC bias, the second harmonic increased less, now almost 6dB smaller than the 25 volt version. Distortion at 0.00460% was just over half that of the 25 volt version.

### Bi-polar tests

The Panasonic S bi-polar capacitor at 0.3 volt with no bias produced less than half the distortion of the 25 volt

## Technical Support

Interested readers are free to build a system for personal use or educational use in schools and colleges. Commercial users and replicators should first contact the author.

A professionally produced set of three FR4 printed circuit boards, with solder resist and legends, for the 1kHz signal generator, output buffer amplifier/notch filter/pre-amplifier and the DC bias buffer network, comprising a 'with DC bias, single frequency, distortion test system', complete with heat bound hardcopy 28 pages A4 assembly notes, parts lists and drawings and with PCB's costs £32.50.

To reduce your costs, I now offer PCB's with the 28 page assembly notes, parts list and PCB drawings, as PDF files on floppy disc, for £30.

If ordered at the same time as either of the above, additional sets of PCBs cost £27.50, but please double the post/packing costs.

The CD ROM with 28 page manual, parts lists, PCB drawings, added distortion measurement results and even more capacitor information but no PCBs, costs £15

Post/packing to UK address £2.50. Post/packing to EU address £3.50, rest of world £5.50.

As a service to non-UK readers, if ordered with the above PCBs, a four gang potentiometer, re-tinned and tested, with each set of boards, costs an additional £5.00 inclusive of postage.

Falcon Electronics tel:01 508 578272 (EW September) has these potentiometers in stock.

Postal Orders or Cheques, for pounds sterling only, to C. Bateman, 'Nimrod' New Road, ACLE, Norfolk, NR13 3BD, England.

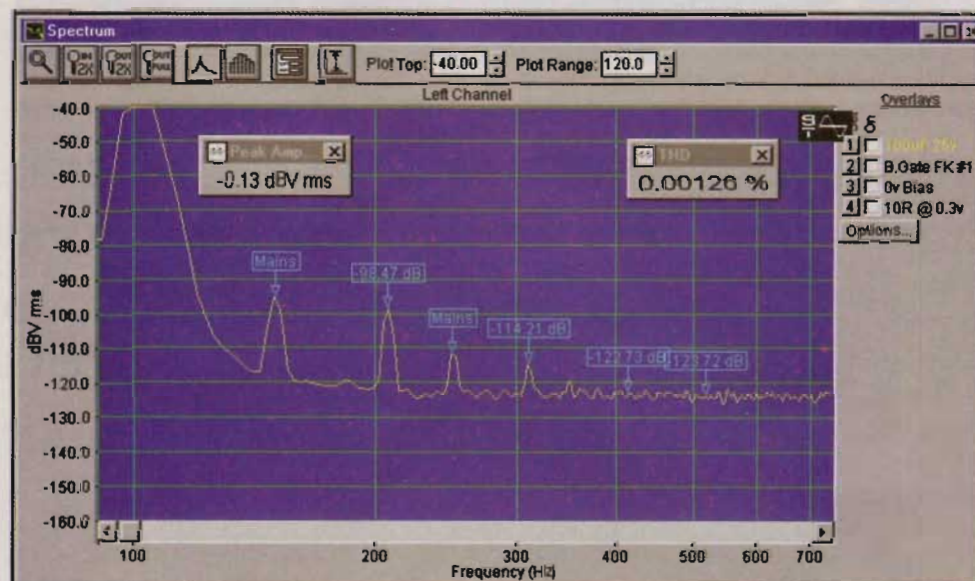


Figure 9: Tested at 0.3 volt with no bias, the 100 $\mu$ F 25 volt Silmic produced the smallest second harmonic, 2dB better than the Black Gate FK shown and 11dB better than YXF. Third harmonic was -112.8dB Silmic, -110.5dB for YXF.

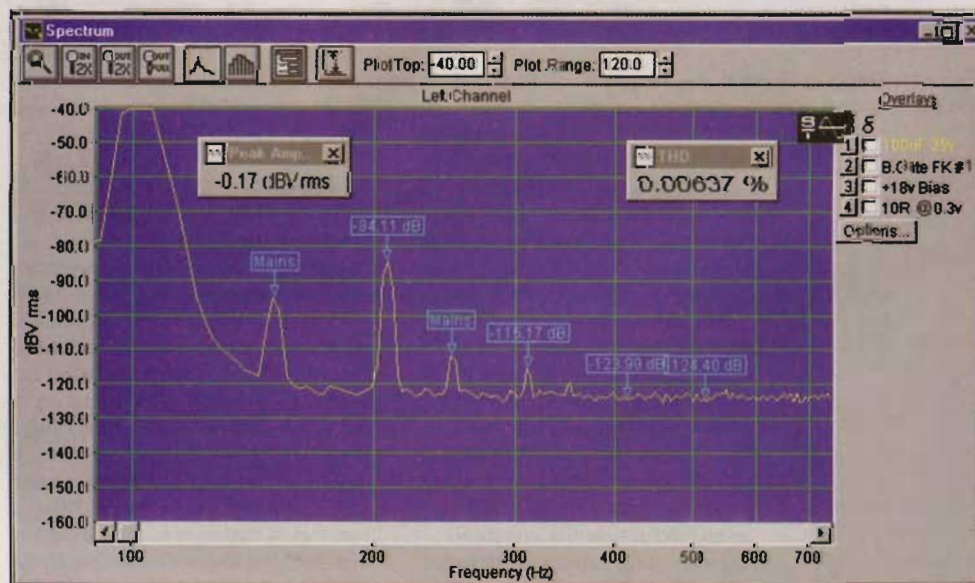


Figure 9B: As Figure 9 with 18 volt DC bias, the Black Gate FK second harmonic increased 14.4dB, distortion is now 3dB smaller than the Silmic but fifteen times bigger than the PET assembly.



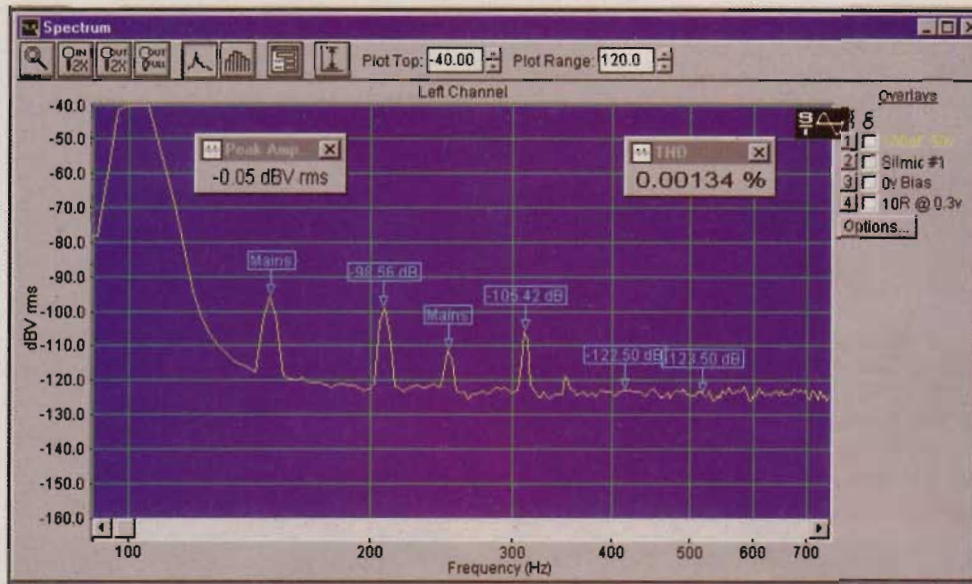


Figure 10: Tested as Figure 9, this 100µF 50 volt Silmic shows 2dB more second harmonic and 7dB higher third harmonic. Its longer foil lengths produced a 35% increase in distortion.

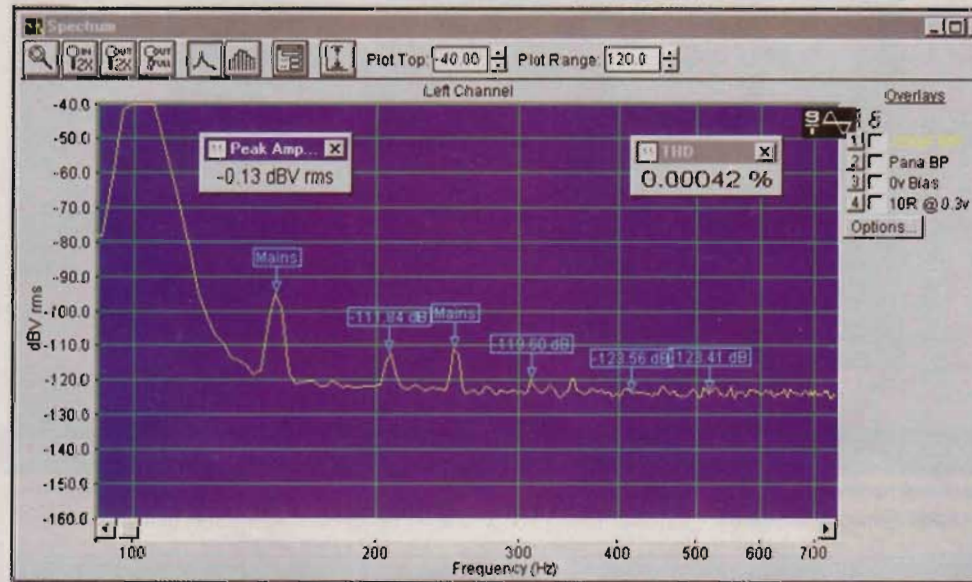


Figure 11: Tested as Figure 9, this 100µF 50 volt Panasonic bi-polar measured just 0.00042%, less than half the distortion of the best polar capacitor.

Silmic. The second harmonic measured -111.8dB, the third -119.6dB and distortion was 0.00042%. With an 18 volt DC bias, the second harmonic increased to -92.7dB and distortion to 0.00237%, that's half the distortion of the 50 volt Silmic.

The Panasonic S bi-polar produced the lowest distortion of all single 100µF electrolytic capacitors I tested, using a 0.3 volt signal and DC bias from 0 volt to 18 volts. Fig. 11.

In my last article we saw how using two polar capacitors in series could reduce distortion. Let us explore using two bi-polar capacitors in series.

**Two better than one?**

I already had some 220µF 63 volt Nitai bi-polar electrolytics, Farnell 317-4906. Two connected together in series would approximate 100µF.

Measured at 0.3 volts with no bias, the second harmonic level was reduced by 6dB compared to the Panasonic S bi-polar. With the second and third harmonics buried in the noise floor, distortion at 0.00033% measured the same as the PET assembly. With 18 volt DC bias, second harmonic measured -105.3dB and distortion 0.00063%. A near four-fold improvement compared to the Panasonic S bi-polar, more than seven times better

than the best polar capacitor tested.

To better compare harmonics we examined performances using a 0.5 volt signal. With no bias, those for my PET assembly can just be seen emerging from noise. The second harmonic was at -124.3dB, the third -123.9dB and distortion was 0.00020%, Fig. 6.

The double 220µF 63 volt bi-polar second harmonic was -117.7dB, the third -124.1dB and distortion was 0.00023%, practically the same distortion as the PET assembly. Fig. 12.

With 18 volt DC bias, the second harmonic of the double bi-polar increased to -100.7dB and distortion to 0.00093%, slightly more than double the distortion measured on the PET assembly with this bias.

This is an excellent performance from electrolytic capacitors, but how does this series pair of bi-polar capacitors stack up for size and cost? Can this bi-polar series pair produce low distortion with a 1 volt signal?

**Double bi-polar v alternatives**

The series pair requires less PCB area, is lower cost and dramatically outperforms a polar capacitor with a film shunt.

At 1 volt with no bias, the noise floor improved to -132dB. Distortion of the PET assembly measured 0.00011%, a single Panasonic S bi-polar 0.00054% and the Silmic 25v with 10µF shunt 0.00151%. The 220µF 63 volt Nitai series pair measured 0.00016%, practically equalling that measured on the PET assembly, ten times less distortion than the Silmic capacitor.

With an 18 volt DC bias, the 220µF 63 volt Nitai series pair distortion measured 0.00217%. Slightly more than six times that of the PET assembly but nearly seven times less distortion than using the 50 volt Silmic polar capacitor. This series pair of 220µF 63 volt Nitai bi-polar capacitors costs one eighth and takes just one fifth the PCB area of my PET assembly. To explore other double bi-polar options, I purchased 35 volt and 16 volt 220µF Nitai bi-polar capacitors for tests.

**Smaller, doubled bi-polar**

With no bias and tested at 0.5 volt, distortion for all three voltage bi-polar doubles measured almost the same as the PET assembly, but 18 volt DC bias revealed large differences. The 16 volt series pair measured 0.00693%, the 35 volt series pair 0.00230% and the 63 volt series pair 0.00093%.

For the lowest possible distortion



when DC blocking/signal coupling, I suggest the 16 volt pair is only used with negligible DC bias, the 35 volt pair be used to say 6 volt bias and the 63 volt pair to say 12 - 15 volts bias. With such small DC voltages, no voltage sharing resistors are needed.

Used in a 'Long Tailed Pair' amplifier feedback network to ensure unity gain at DC, the 63 volt series pair could be used with supply rails up to 63 volts, without voltage sharing resistors. For higher voltages use a series pair of 100 volt bi-polar.

This 63 volt series pair can also benefit local supply rail decoupling, but for this use, voltage sharing resistors, passing a few milliamps from the supply to the capacitors central connection and ground, must be used.

### Conclusions

Having measured a considerable number of aluminium electrolytics using test voltages from 0.1 volt to 3 volt, with and without bias, a single bi-polar type produced lower distortion than larger, more expensive, specialist polar capacitors.

Much better results were obtained by connecting two double value bi-polar electrolytics in series. Using 1 volt or smaller test voltages and no bias, distortions for a double bi-polar and the metallised PET assembly were similar.

With increasing bias or with increasing test voltage, the metallised PET assembly produced less distortion than any electrolytic I tested.

### 100µF choice

Provided the AC voltage developed across the capacitor at the lowest audio frequencies is 1 volt or less and no significant DC bias is used, a double bi-polar series pair provides an economic solution.

When higher AC signal voltages, especially combined with significant DC bias, must be applied, the metallised PET combination produces less distortion. It costs eight times more and takes five times more PCB area than the double bi-polar.

For the least practical distortion, an assembly of metallised Polyphenylene Sulphide capacitors might be feasible. It needs double the board area and is five times more expensive than the PET assembly.

For small AC signals with modest DC bias and for supply rail decoupling, I choose the double bi-polar 63 volt solution.

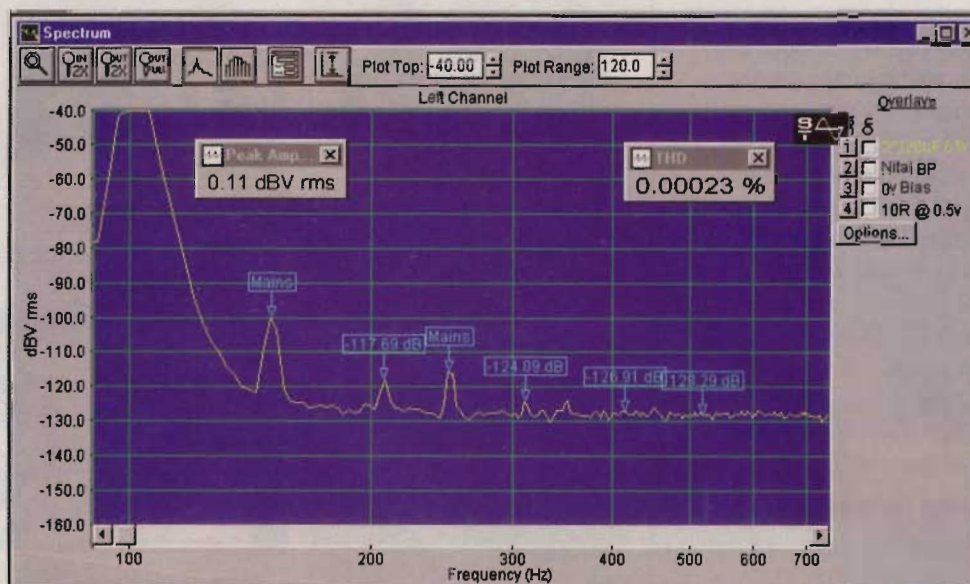


Figure 12: A series pair of 220µF 63 volt Nitai bi-polar capacitors with 0.5 volt test signal. With no bias distortion was similar to my metallised PET assembly, five times smaller than the best polar capacitor tested. With 18 volt DC bias, 0.00093% distortion is nine times smaller than the best polar capacitor.

### ESR/tanδ

The most nearly perfect capacitor would exhibit near zero ESR. Low ESR is essential for use in switched mode power supplies, but does a low ESR electrolytic ensure low audio distortion?

Of the 100µF capacitors I tested, the 10 volt Oscon measured the lowest 100kHz ESR of all, 0.012 Ohms and 100Hz tanδ of 0.035. It would be unreasonable to compare a 10 volt capacitor with higher voltage types so I also measured 10 volt Rubycon YXF and Elna RSH types. The YXF

ESR measured 0.550 Ohms and tanδ 0.091. The RSH ESR was similar, at 0.505 Ohms and tanδ at 0.104.

Tested at 0.5 volt with and without 6 volts DC bias, the Rubycon YXF produced the least distortion, 0.0351% with DC bias and 0.00331% unbiased. The Oscon distorted worst of the three, measuring 0.05321% with DC bias and 0.02499% unbiased.

Clearly low tanδ at 100Hz and low ESR at 100kHz does not ensure low audio distortion.

### 10µF choice.

We have three possibilities. A double bi-polar using two 22µF 50/63 volt bi-polar electrolytics, a 10µF metallised PET or an assembly of three 3.3µF PPS capacitors.

The lowest cost solution for use with signal voltages less than 1 volt and no significant bias is a double bi-polar series pair. A 10µF MMK metallised PET takes the same PCB area and distorts less with DC bias.

The PPS capacitor assembly ensures lower distortion, especially when used with increased AC signals or DC bias voltage. However it occupies more board area and is expensive.

An assembly of Polypropylene capacitors, as used in the DC bias network, would provide the lowest possible distortion, but requires a five times larger board area and is most expensive.

For small AC signals and modest

DC bias, I choose the 10µF MMK metallised PET capacitor. ■

### References.

1. Capacitor Sound part 5 C. Bateman EW December 2002 p.44
2. Capacitor Sound? C. Bateman Electronics World July 2002 p.12
3. Capacitor Sound 2 C. Bateman Electronics World September 2002 p.16
4. Understanding capacitors - aluminium and tantalum Electronics World June 1998 p.495. C. Bateman
5. Evaluate capacitors for SMPS designs. C. Bateman Electronics World Sept 2000 p.696
6. Reference Data for Radio Engineers. Howard Sams & Co. Inc. New York

Certain aspects of this article are the subject of a patent application.